

# Power Line Carrier Communication Based Data Transmission for Tele-Operation of Devices

<sup>1</sup>Sundari.B, <sup>2</sup>Nandhini.N, <sup>3</sup>Agila.G

<sup>1</sup>Assistant Professor, Dept of ECE, Jayam College of Engg & Technology, Tamilnadu, India.

<sup>2,3</sup>UG Student, Dept of ECE, Jayam College of Engg & Technology, Tamilnadu, India.

**Abstract - Power Line carrier Communication or Power Line Carrier (PLC) is a technology that it works narrow or broad band speeds through power lines by varies advanced modulation technology. This PLCC modem works in based on the principle of controlling or each electrical device has connected to an electrical socket with the existing power line in the building. In this project, the main purpose of developing PLCC based control using power line communication is because this technology doesn't require extra cabling. It only uses an existing power line cable in the building. Hence, the user doesn't have to restructure their cabling system which is very inconvenient and costly. User will be able to control any electric appliances that plug in to the power line interface socket. Besides that, one can able to control and monitor the device through power line interface socket.**

**Keywords:** PLCC, Power Line Carrier Communication, Tele-Operation, Data Transmission.

## I. INTRODUCTION

The telephony of many small businesses is the means by which they interact with their customers and their staff. These companies use small telephone systems for their daily activities, but most of the systems available are designed to accommodate a large number of users and are extremely expensive. This system is a solution for those who are developing small businesses and businesses around the world who are looking for a reliable and inexpensive way to communicate. It describes a communication approach that can ultimately be used to transmit data over a power transmission network [1]. The energy transfer is carried out according to the principle of superposition of voice on the energy in the cables of electric lines.

The flow of communication is today very high. Many applications operate at high speed and often require a fixed connection. If a power line network is used as a channel or means the provision of a power line to customers, this can be a breakthrough in communications [2]. Since electrical communication provides real-time data transmission services

and is one of the most cost-effective forms compared to other communication systems, it uses the existing low-voltage grid in every building connected to the building. installation of new cables, mainly for internal applications. This technology allows the connection between various devices by connecting each of them to an electrical source installed in each room of the house.

The power line approach, which can ultimately be used to transmit data via a low voltage power line network, is described. In a data line system, the AC transmitter transmits a data signal with a 50 Hz power line. The receiver only accepts our data signal and rejects all other signals. A data transmission system generally operates by superimposing a modulated signal on an AC signal present on the power line [3]. The superposition principle will apply to signals when two or more signals cross the same channel at the same time. The signals pass through the normal environment without disturbing each other.

## II. LITERATURE SURVEY

Power line communication has been around for quite some time, but has only been used for narrow band tele-remote relay applications, public lighting and home automation.

Broadband over PLC only began at the end of the 1990s:

**1950:** at a frequency of 10Hz, 10kW of power, one-way: town lighting, relay remote control.

**Mid 1980s:** beginning of research into the use of the electrical grid to support data transmission, on bands between 5 - 500 KHz, always in a one-way direction.

**1997:** first tests for bidirectional data signal transmission over the electrical supply network and the beginning of research by Ascom (Switzerland) and Norweb (U.K.)

**2000:** first tests carried out in France by EDF R&D and Ascom.

**Power lines are classified into three types:**

- Short range: 0-80km
- Medium range: 80-250km
- Long range: more than 250 km

There were some literatures published on the analyzing of the radiation of PLC under wide frequency range. However, so far as we know, none of them was related to the PLC through the 3-line indoor power supply transmission line [4].

### III. EXISTING SYSTEM

In this work a power line technology is demonstrated that can be utilized for transmitting a data by means of a simple power line communication interface. The results obtained are promising in such way that the power line can also be utilized for high speed mode of data transfer. The outcome of this work will be used as a part of such product that can be connected to any group of devices which can be connected to a power line [5].

### IV. PROPOSED SYSTEM

The main aim of this project is to design and develop a Tele-operated control system in real time using the power lines such that it can communicate with maximum efficiency and user can monitor them using a display unit. A PLCC transmitter unit is designed which sends data to a remote

receiver unit which can control the loads according to the commands send by the user. The user uses a keypad to send ON, OFF commands to the receiver. The transmitted data and status of devices can be displayed in a LCD display.

#### a) Block Diagram of Proposed System

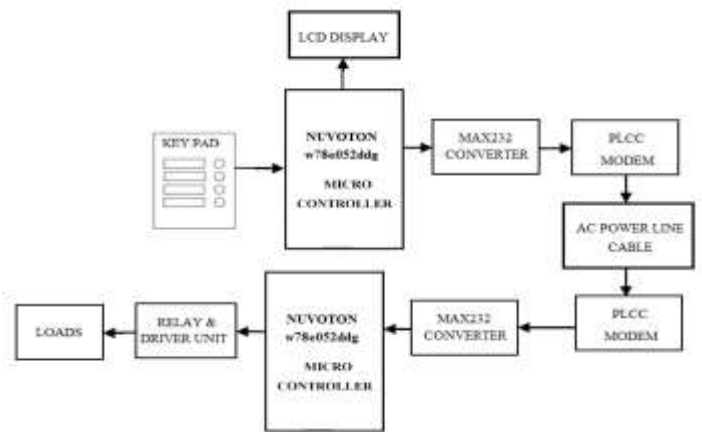

Figure-1: Block diagram of proposed system

#### b) PLCC Modem Circuit Diagram

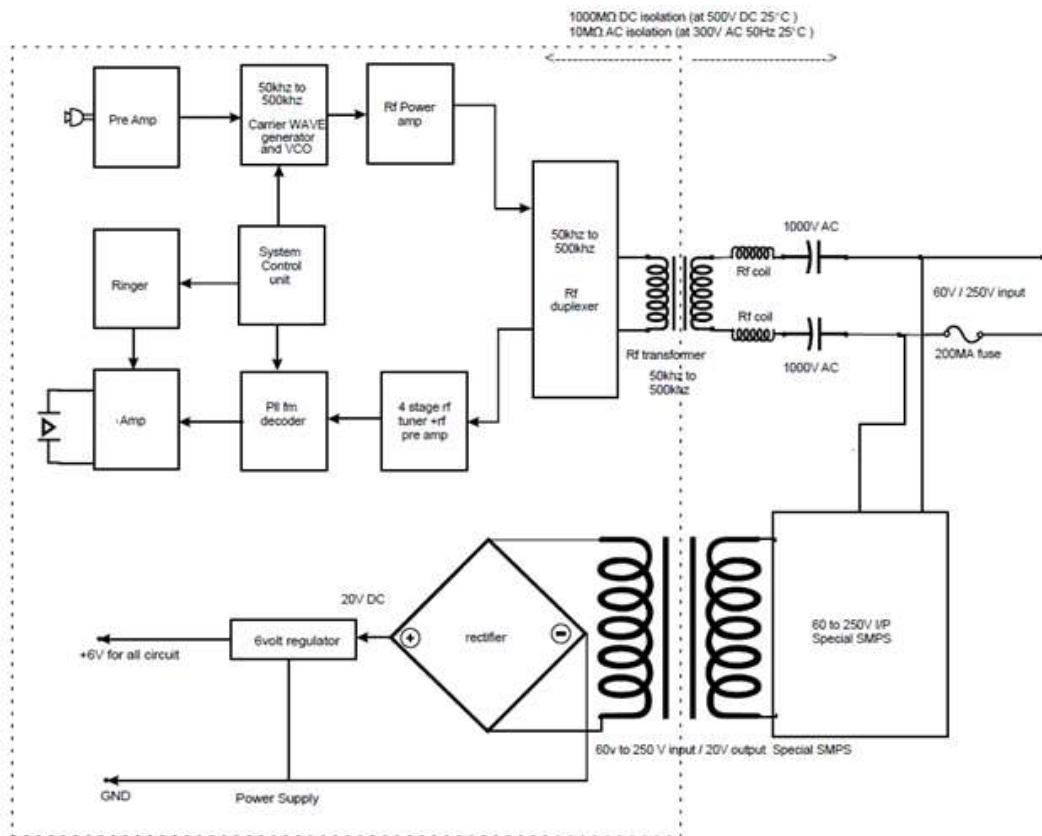

Figure-2: Circuit Diagram of PLCC Modem

**c) Description**

The master, which has a display (LCD) and an input console (card), is connected to the power line on the sending side to transfer data to slave devices at the other end of the line. The master has the necessary characteristics to code, modulate the controls before they are sent on the power line, while the slave device is designed to demodulate and decode commands received from the power line. Both units have a microcontroller for data processing and a PLCC modem for modulating and demodulating data with a carrier signal. The FSK modulation method is used with a carrier frequency of 125 kHz. The command is transmitted from the transmitter module and the devices are controlled according to the received command. The status can be displayed on the LCD screen.

The data transmission on the power line is illustrated as shown in the figure. When transmitting data over a power line, the module used to transmit the signal is also used for reception. A voltage control generator (VCO) present in the phase locked loop circuit (PLL) is used to modulate a signal during transmission. The same PLL is used to demodulate the signal when the module is operating as a receiver. As a result, when the receiver is aligned, the transmitter automatically aligns. The speaker used to receive the data also serves as a sound signal to alert the user.

**d) PLC Transceiver**

This Phase Locked Loop block transmits and receives data signals, hence PLL is bidirectional and controlled by a switching block Duplexer. For receiving mode of PLC, the ring tone is fed to RTG (Ring Tone Generator) unit to alert the party. If called party lifts the hand set to modem, PLC switches to transceiver mode and hence allows both parties to make a conversation.

**d) Duplexer**

The duplexer is nothing but a multiplexer it acts as a digital switch. When the data signal is modulated while transmission, the Duplexer changes the PLL into transmitting mode and while receiving the data signal is demodulated the duplexer changes the PLL into the receiving mode.

**V. SYSTEM DESIGN**

**Circuit Diagram of PLCC**

The main function of power line is distributing of electric energy to distance. Here a new signal is injected to power line at high frequency. FCC rule said that frequency range between 65 kHz-75 kHz only we can be used for data or signal transmission over power line. The modulator circuit which sends data signal encoded in FM mode through power line and a receiver to decode it from.

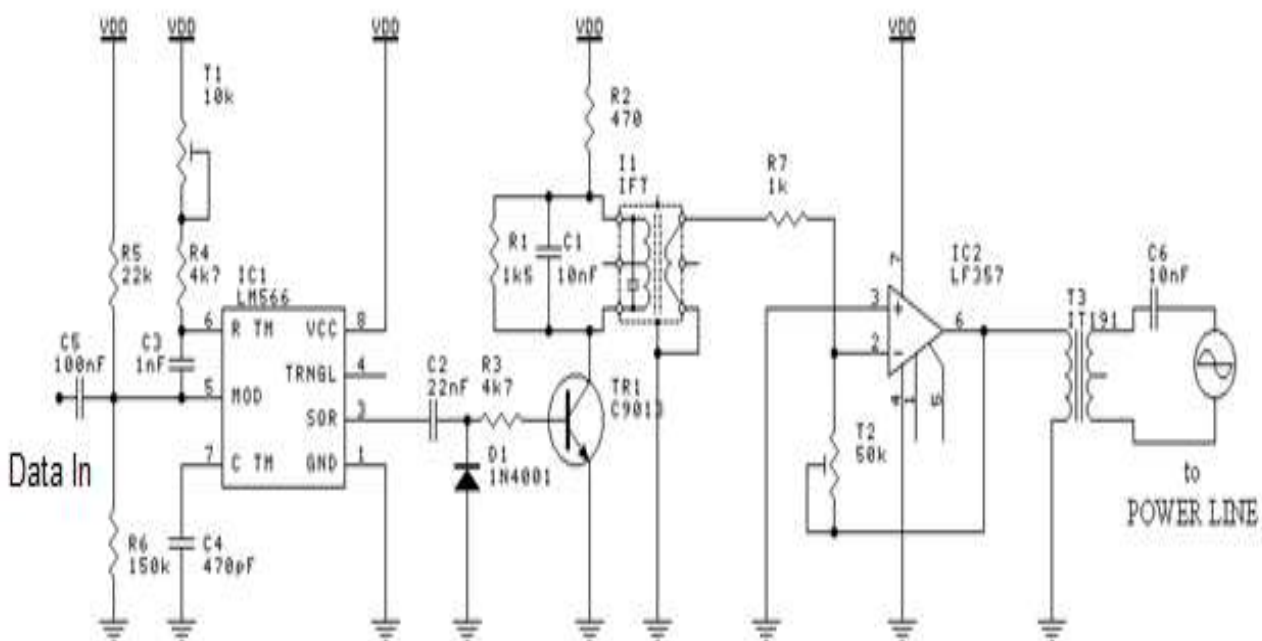

Figure-3: FM Modulator and Data Transmitter Circuit

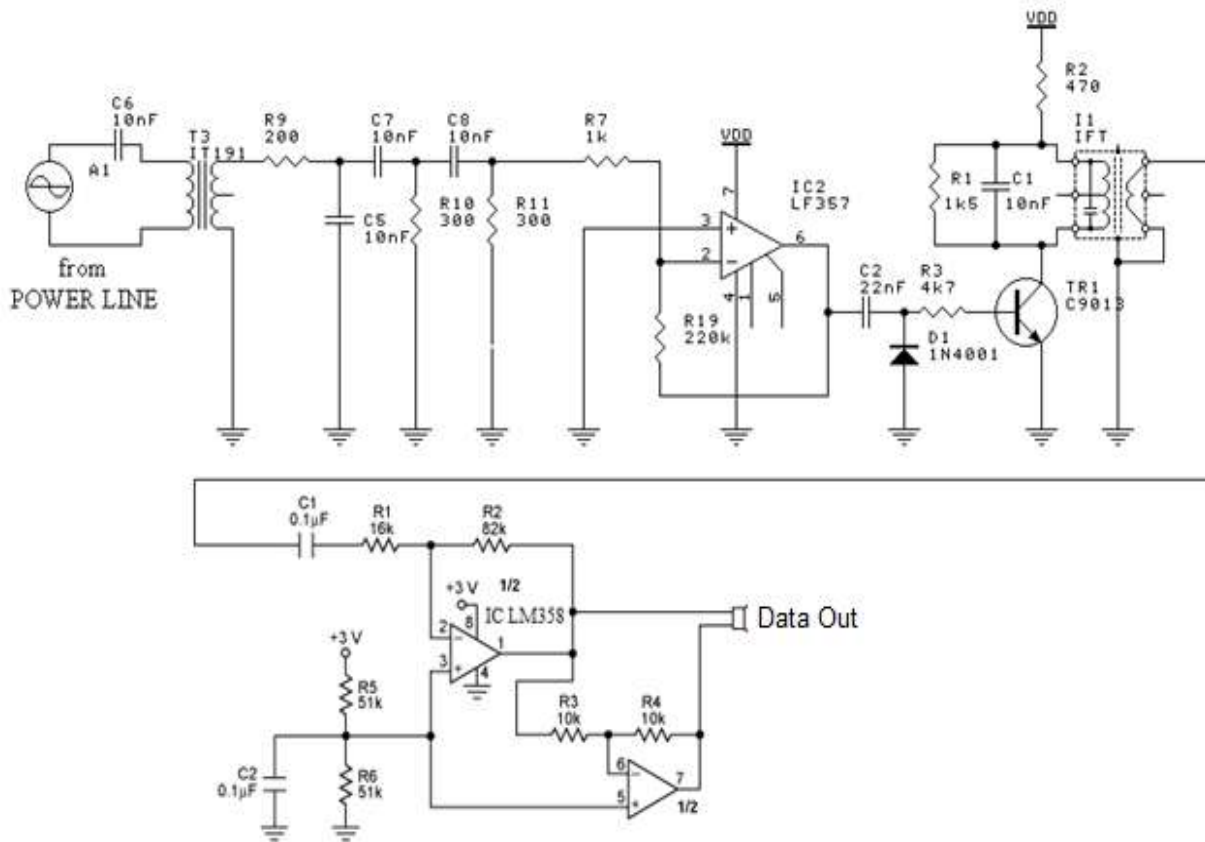

Figure-4: FM Demodulator and Data Receiver Circuit

Electric power that runs at power line has a shape of sinusoidal, in electrical ways it contain amplitude and frequency. The injected signal may not annoy the main signal, so the amplitude is maintained low. There are always noises at the line so that the signal amplitude must be small but large enough compared to the noises. The range permitted in modulation involved in this case of frequency modulation method is 70 kHz as the carrier frequency.

The typical applications of in-house power-line data communication is that, this system allows easier and more efficient Data communication between the end users inside a building.

## VI. RESULT AND DISCUSSION

This is the most important part of PLC that should be designed very carefully. As the modulated signal is transmitted over power line and a 220Vac (50 Hz) already existing there so it is needed to isolate the 220Vac (50 Hz) from our transmitter and receiver circuit for protection.

**Power line isolation:** To isolate the 220Vac (50 Hz) signal it is needed to apply a high pass filter to allow the high frequency modulated signal to pass through while blocking the

low frequency signal. Here a high voltage low valued capacitor is used in series with a coupling transformer between the power line and the transmitter or receiver. This will block any signal of a frequency lower than the cut off frequency and allow passing any signal having a frequency greater than the cut off frequency.

**Line Trap:** The line trap circuit is used for allowing the transmitted signal to receive over a limited area such as a building, institution, market or a town. There may thousands of devices connected over the power line at a time. So there may have a great signal loss of our transmitted signal. To reduce this loss it is needed the line trap circuit.

The line trap circuit has been used in series with the power line which actually consists of a parallel inductor and capacitor. For the 50 Hz ac signal of power line it gives very lower impedance but for our 150 KHz carrier signal it gives high impedance. So there is no restriction for 50 Hz ac signal of the power line but due to high impedance for carrier signal the line trap circuit will not allow to pass the transmitted signal out of the area bounded by the line trap circuit.

## VII. CONCLUSION

The power line data communication system is designed and prototype is tested, which highlights the advantage of using power-line as transmission medium for in-house communication. Implementation of this system provides affordable and easy to install hardware. PLC allows user to work their existing electrical wiring to connect to the variety of electrical devices. Hence it does not require any separate wiring for the use of data communication. Mobility is a major advantage in this system that will help for occasionally-connecting for communication and removing when not in use. Also our design provides flexibility where power-line communication extends connectivity to all electrical outlets in the home which same electrical points that will provide power serves as access point for the network devices.

## REFERENCES

- [1] N. Ginot, M. A. Mannah, C. Batard, and M. Machmoum, "Application of Power Line Communication for Data Transmission Over PWM Network" *IEEE transactions on smart grid*, vol. 1, no. 2, pp. 178-184, september 2010.
- [2] J. Serrao, A. Fakih, R. Khatik, "Transmission of data using power line carrier communication system" *International Journal of Electronics Communication and Computer Technology (IJECCCT)*, Volume 2, pp. 280-283, Issue 6, November 2012.
- [3] J. J. Lee, C. S. Hong, J. M. Kang and J. W. K. Hong, "Power line communication network trial and management in Korea" *International journal of network management*, *Int. J. Network Mgmt* 2006; 16: 443– 457, Published online in Wiley InterScience, (www.interscience.wiley.com) DOI: 0.1002/nem.632.
- [4] H. He, Student Member, IEEE, S. Cheng, Senior Member, IEEE, Y. Zhang, and J. Nguimbis, "Home Network Power-Line Communication Signal Processing Based on Wavelet Packet Analysis" *IEEE transactions on power delivery*, vol. 20, no. 3, pp.1879-1885; July 2005.
- [5] S. M. Singh, Esq. Ratepayer Advocate, State of New Jersey, Division of the Ratepayer Advocate, 31 Clinton Street, 11th Floor, Newark, New Jersey 07102; "Broadband over power lines A white paper". pp. 35.

### Citation of this article:

Sundari.B, Nandhini.N, Agila.G, "Power Line Carrier Communication Based Data Transmission for Tele-Operation of Devices", *International Research Journal of Innovations in Engineering and Technology (IRJIET)*, Volume 2, Issue 2, pp 37-41, April 2018.

\*\*\*\*\*