

# AC-AC Solid State Transformer Based on Single Conversion Stage

<sup>1</sup>R.Yalini, <sup>2</sup>S.Sanathi, <sup>3</sup>S.Velmurugan, <sup>4</sup>M.G.Yogapriya

<sup>1</sup>HOD/Associate Professor, Dept. of EEE, Jayam College of Engineering and Technology, Tamilnadu, India

<sup>2,3,4</sup>PG Scholar, Power Electronics and Drives, Jayam College of Engineering and Technology, Tamilnadu, India

**Abstract** - Single phase solid state transformer (SST) has received great attention among researchers and engineers as an effort to replace the standard 50/60Hz low frequency (LF) transformer in certain applications where bulky and heavy low frequency transformer become prohibitive. The main challenge in SST research is how to achieve comparable efficiency and high reliability of the traditional LF transformer. The heavy and bulky low frequency (LF) transformer single phase (50/60 Hz) has long been a proven technology as a solution for providing power delivery in wide range of power rating and voltage rating. However, in applications where the physical dimension of transformer is a limiting factor for its utilization such as in aerospace application, solid state transformer (SST) becoming an interesting alternative to the LF transformer. To significantly miniaturize the physical dimension of the transformer, SST operates at high switching frequency by utilizing power transistor to convert the low frequency power into high frequency power which can be efficiently transferred with much smaller transformer. Based on that target, a single stage single phase SST was developed with separate high frequency converter link (HF-Link) and low frequency commutation bridge (LF-Bridge). The HF-Link was realized using full bridge converter. In this project, our experience in developing single phase SST will be presented along with the lesson learned during the development. A converter structure based on separate high frequency converter link and Low Frequency Commutation Bridge was studied, tested, and analyzed. From the experimental measurement, the prototype converter was able to provide clean sine wave power to the load with conversion at the 1kW maximum load.

**Keywords:** AC-AC, Solid State Transformer, Single Conversion Stage, LF-Bridge, SST.

## I. INTRODUCTION

Nowadays the electrical main grid is managed in AC due to several reasons derived from the past. Recent years have experimented a rapid evolution of power electronic components able to dramatically enhance the effectiveness of

the active and reactive power flow management. The inverter diffusion makes possible the intelligent integration between systems with different characteristics (i.e. in terms of voltage magnitude and frequency) and the exploitation of generation sources and storage systems typically operating in DC. One of the most interesting components able to interconnect different portions of electrical networks is the Solid State Transformer. The Solid State transformer is formed by few static power converters that operate sinergically and are connected in series with a high frequency transformer. Different voltage levels are made available to achieve high results in terms of system integration, efficiency and flexibility. Taking advantages from the described component structure and main features, in this paper the authors aim to evaluate the main potentials of this technology if widely introduced in the main power system. Starting from the single component description, a couple of possible applications are presented and discussed in terms of assets and weak points.

A commercial power system has three main structural components, namely generation, transmission and distribution. Each of these components is characterized by a specific voltage level based on its function in the power system. Thus, it is necessary for the utility to transform the electrical power from one voltage level to another. Transformers are employed to serve this purpose, making them an essential structural element of power system. The research in transformer technology is directed mainly towards development of new magnetic, conducting and insulating materials in order to reduce losses and to match the required transformer rating.

In the past few decades, deregulation of power generation is being considered as a viable option to meet the increasing power demands. The deregulation policy has resulted in increased penetration of distributed energy resources (DER) in the distribution system which is now causing power quality issues. The harmonics introduced in power system by DERs are posing challenges for transformer design. Integration of DER also causes problems of over-voltage or under-voltage. Though use of tap-changers enables the transformer to control the terminal voltage, there are limitations on both - the voltage control margin and the frequency of operation of the tap changers.

In the past few decades, with the technological advancements in solid state physics, power electronics has emerged as a promising solution to deal with the problems of complex power systems. The high power and controllable solid state switches have triggered development of various power electronic converters which find application in both transmission and distribution systems. A review of HVDC technology which finds application in long distance or submarine power transmission is presented. The use of FACTS converters for maintaining power quality in distribution network is gaining popularity. On similar background, the possibility of developing a solid state transformer (SST) for high power applications is being considered for past decade.

Thus, with a specific topology of converters used in SST, it is possible to offer enhanced power quality by reducing harmonics or by reactive power compensation. Also it could be noted that, presence of an intermediate DC link makes SST suitable for use in DC micro grids.



Figure 1: Size comparisons between low-frequency and high-frequency transformers

In 2011, MIT technology review regarded SST as one of the top ten emerging technologies and presently, research in this field is being promoted by Future Renewable Electrical Energy Delivery and Management (FREEDM) Systems Center at North Carolina State University, Raleigh. Numerous attempts of developing laboratory prototype of SST are documented. The power electronic converters in SST also enable it to perform additional functions such as regulation of voltage and current which cannot be achieved by means of a conventional transformer.

### Application of the SST as MV/LV

#### Interconnection

With the growing number of dispersed generators connected to the MV e LV networks, some issues in the distribution networks operation have to be faced. In this, the SST adoption in alternative to traditional industrial frequency transformer can represent an interesting solution. A conceptual representation of the proposed scheme is reported in Figure below.

In particular, losing the close relationship between the LV side behaviour and the MV side absorption by interposing two controllable DC links, a better control of the entire distribution grid is facilitate:

The above discussed advantages in terms of supplied voltage and frequency stability, power quality, heartlessness to network events and perturbations are confirmed also in case the SST is adopted to interconnect the MV and the LV distribution networks.

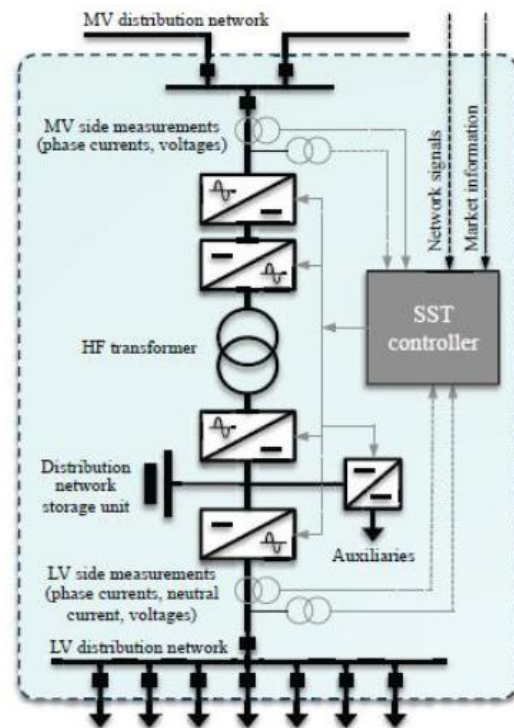

Figure 2: Application of the SST concept as MV/LV interconnection

A SST can regulate the MV/LV ratio in accordance with the network operating conditions, facilitating the voltage control of the LV system independently from the MV voltage level. A sort of dynamic On Load Tap Changer (OLTC) is obtained. The voltage ratio, independently adjustable phase by phase, can be set in wide and continuous range of values in accordance with the voltage regulation issues or to obtain a partial regulation of the load consumption, considering a traditional ZIP model (impedance, current, power).

#### SST based DC Microgrid

In addition to its compactness, the SST technology offers operational compatibility with the future power systems having high penetration of DERs and artificial intelligence. The recent developments in PV technology, DC energy storage devices and various DC loads have highlighted the concept of a DC microgrid which increases the overall

efficiency of the power system by avoiding unnecessary conversion.

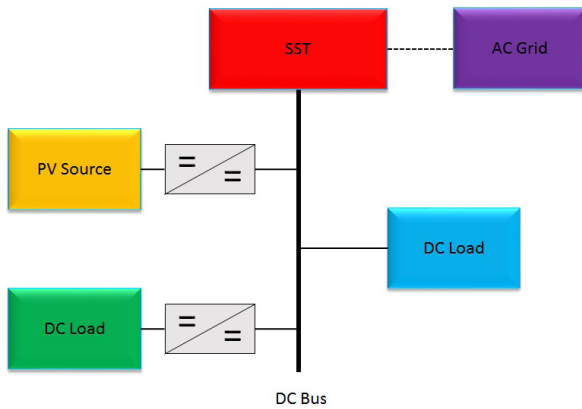

Figure 3: Schematic Diagram for DC microgrid integrated with AC grid using SST

A zonal microgrid architecture using SST is proposed which utilizes maximum power from PV and energy storage devices while maintaining power quality and stability of the microgrid. A block diagram of the proposed microgrid architecture is shown in Fig. 5. The three stage SST is controlled using decoupled dq control. The DC link voltage of both the links is maintained using appropriate control strategy. The battery is subjected to suitable charging and discharging cycles based on its state-of-charge (SOC) to increase the battery life.

## II. EXISTING SYSTEM

Conventional line-frequency transformer (LFT) in many applications, such as in electric traction, renewable energy systems, and smart distribution grids, issues like low efficiency, low power density, and poor reliability are still major challenges for its industrial applications, and most of the research works aim at addressing these issues.

### Drawbacks

- Increased size, weight and cost in Low frequency Transformer Designs
- With High Frequency transformers efficiency get reduced and implies higher cost
- Increased complexity and amount of semiconductors
- Limited Power levels
- Poorer performances at light loads conditions because of the transformer magnetizing current
- Leads to magnetic core saturation and then to harmonic distortion of input and output currents

## III. PROPOSED SYSTEM

In this proposed system, we put our focus to only single stage SST design to study its characteristic and operation method. The design of single stage SST is divided into two parts, first part is high frequency converter link (HF-Link) and second part is low frequency commutation bridge (LF-Bridge). The HF-Link is used to perform the isolated power transfer from the primary side to the secondary side with high conversion efficiency using soft-switching converter topology, while the LF-Bridge is used to accommodate the unipolar power transistor to perform power conversion on the bipolar input voltage. In this paper, the design for both HF-Link and LF-Bridge was studied and a converter prototype was developed to verify the selected converter structure. The prototype was tested with 220Vrms input and output voltage at 3kW maximum output power successfully.

### Advantages

- AC-AC SSTs are possible to achieve higher efficiency, higher power density and higher reliability due to fewer conversion stages and the absence of energy storage elements.
- Transformer less inverters offers a better efficiency, compared to those inverters that have a galvanic isolation.
- HB-ZVR (H-bridge zero-voltage state rectifier) with the implemented PWM strategy, ideal for PV systems that supply the grid with active power.
- Power factor is maintained at unity.
- These PV inverters are current controlled, injecting only active power into the utility grid.
- Decreased the size of the output filter.

## IV. SYSTEM DESIGN

### Block Diagram

Single phase AC-AC single stage SST is consisted of HF Bridge Inverter-Link and LF-Bridge rectifier. The HF bridge-Link can be realized by using half-bridge or full bridge inverter for the it's primary and secondary side depends on the required power rating. The LF-Bridge is a bridge rectifier.

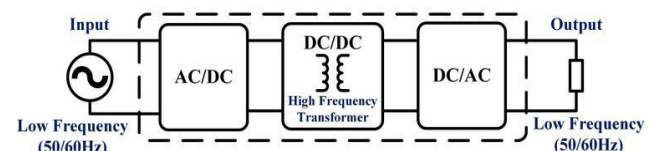

Figure 4: Solid State Transformer Block Diagram

The main AC supply is given to the LF bridge rectifier and converted into DC voltage. Which is then filtered using a capacitor filter. The input is now converted into AC to DC. Now the DC is fed to the HF Full bridge inverter. The inverter

converts the DC into AC output which can be step down according to the required line voltage.

### Circuit Diagram

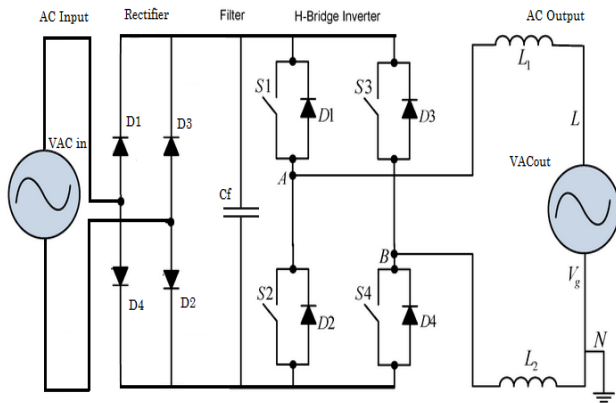

Figure 5: Solid State Transformer Circuit Diagram

The AC-DC conversion stage connects the grid with the DC link at the grid side. If the grid operates at medium voltage, high voltage power switches are required to build the AC-DC converter. It consists of a bridge rectifier made of diodes D1, D2, D3 and D4. The input AC current is rectifier by this full bridge rectifier. The second stage is the filter. It consists of a capacitor filtering which removes any AC components and provides a smooth DC output. Then the third stage is a H-bridge inverter. Here a Full-Bridge inverter is used. It consists of four switches S1, S2, S3 and S4. The switches are operated using a PWM trigger pulses which operated the inverter at high frequency which is of 200KHz. The output of the bridge is connected to the inductors L1 and L2 which provides an AC output voltage across them.

### System Implementation

The proposed structure of the domestic multi-link distribution scheme is fundamentally composed by:

- i) An AC network interface (single-phase 230 V), with traditional distribution to internal loads without galvanic insulation;
- ii) A Low Voltage DC link, with rated value of few hundred Volts, for the supply of high power devices, as principal loads (e.g. washing machines, induction cooking systems, air conditioners, heat pumps, etc.), local generation systems (e.g. photovoltaic, domestic wind plants, fuel cells, etc.), battery storage systems and bidirectional chargers for electrical vehicles;
- iii) An Extremely Low Voltage galvanic insulated DC link for lighting, safety appliances and specific rooms supply, as bathrooms, children rooms, etc;

From the power system perspective, the optimal design of the SST aims to maximize the AC/DC domestic distribution advantages, both in terms of main structure and rated values (which means primarily the voltage levels of all the AC/DC links). This can be done by considering:

- i) The ongoing evolution trends of main appliances, local generators, storage systems and electrical vehicles exploitation;
- ii) The overall efficiency of the entire domestic domain.
- iii) The health protection, safety and electromagnetic pollution.

As regards to other solutions operating at industrial frequency, the SST seems an advantage by the high frequency internal transformer, the SST guarantees the galvanic insulation without a dramatic impact on domestic spaces, being easily installable close to the energy meter and the end-user main protection.

Several advantages in comparison with the traditional domestic plant are easily identifiable:

- The DC system advantages combined with the galvanic insulation are perfectly exploited in terms of voltage and frequency stability for the supplied appliances, both in DC and in AC. Network perturbations, as voltage drops, transient phenomena and over-voltages, can be filtered in order to enhance the Power Quality for sensible appliances;
- Adopting an increased voltage level (few hundreds Volts) for the main DC link supplying the high power appliances and devices, network losses are reduced by both the reduction of circulating currents and the rejection of the reactive component;
- An Extra Safety DC section is introduced for reducing the human exposition to the electrical risk in case of critical appliances, end-users or rooms. A dramatic reduction of the short circuit currents are attended since they are limited by the electronic converters in a very short time;
- Various systems can be integrated, allowing the domestic plant to operate as a unique entity as regards to the main grid and the market. A perfect control of the active and reactive power exchanged with the distributions system is guaranteed by the converter controllers. On the end-user side, the SST can operate as energy gateway in accordance with the home automation environment.

## V. RESULT AND DISCUSSION

### Component Parameter Specification and Format

The parameter dialog window in each component in PSIM has two tabs: Parameters and Other Info, as shown below.

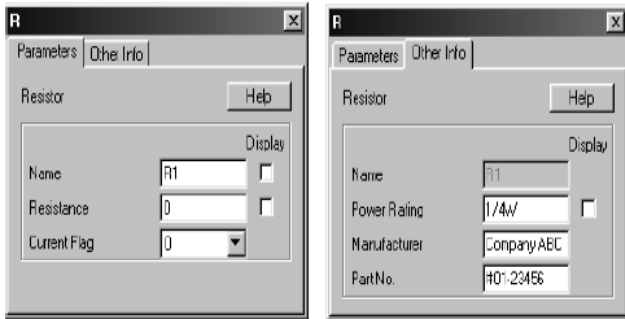

Figure 6: PSIM Component Parameter and Specification

The parameters in the Parameters tab are used to perform the simulation. The information in the Other Info tab, on the other hand, is not used in the simulation. It is for reporting purposes and will appear in the parts list in View Element List in SIMCAD. Information such as device rating, manufacturer, and part no. can be stored under the Other Info tab.

### Circuit Schematic Design Using SIMCAD

SIMCAD provides interactive and user-friendly interface for the circuit schematic design. The following figure shows a rectifier circuit in the SIMCAD environment.

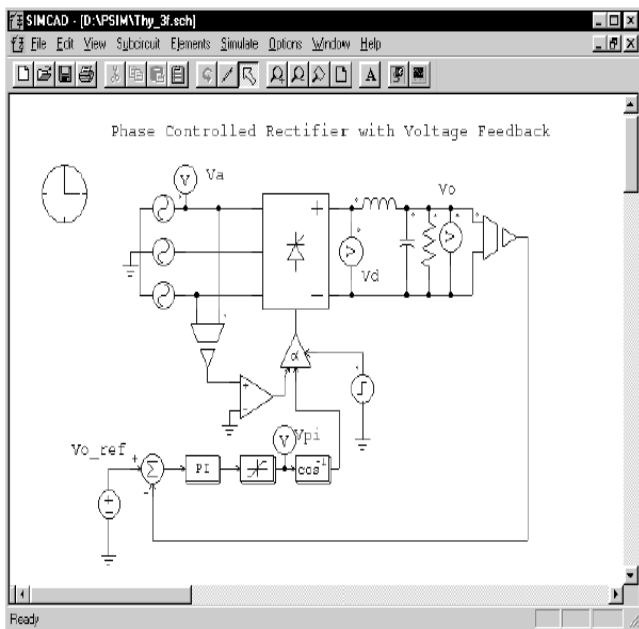

Figure 7: SIMCAD Window Schematic

### AC-AC Solid State Transformer Simulation Circuit

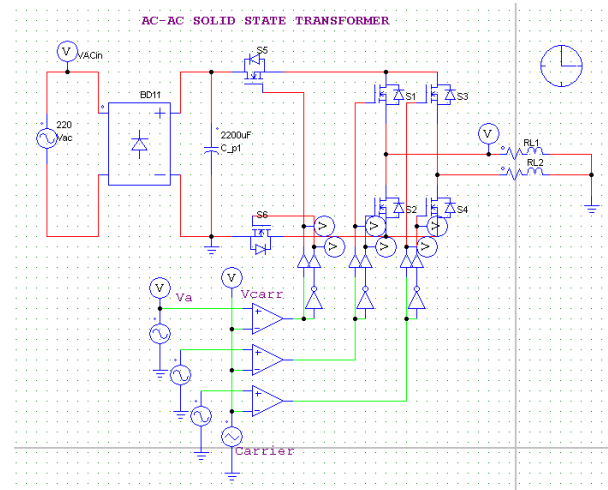

Figure 8: AC-AC Solid State Transformer Simulation Circuit

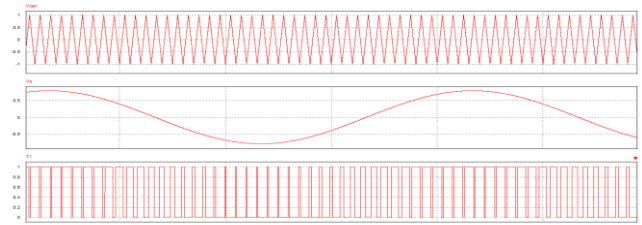

Figure 9: PWM Pulse Generation

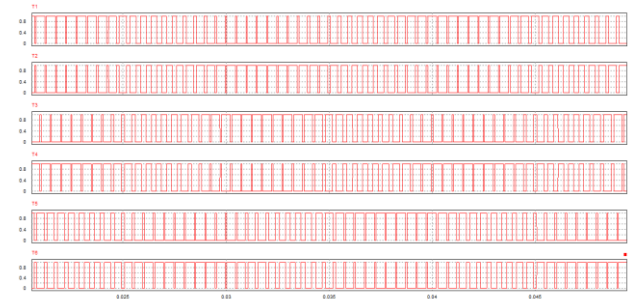

Figure 10: Gate Trigger Pulses of H-Bridge Inverter

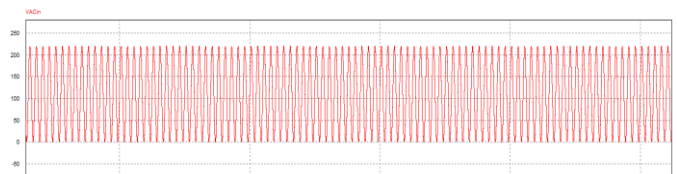

Figure 11: AC Supply Voltage Input

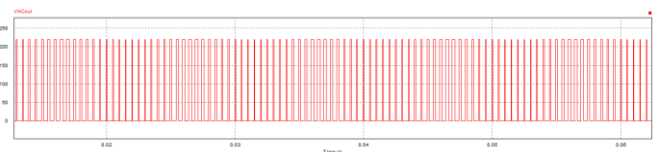

Figure 12: AC Supply Voltage Output

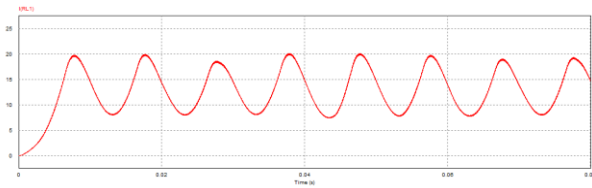

Figure 13: AC Load Current Output

## VI. CONCLUSION

In this project, a single stage AC-AC solid state transformer was designed and simulated. A single-stage AC-AC SST solution without bulky energy storage elements are analysed comprehensively. Because of the lower switching losses of the inversion stage, the efficiency of the presented AC-AC SST is obviously higher than that of the work previously presented. The simulated waveforms show that shows the SST input and output voltage and current waveform is very smooth with very low distortion. The advantage of selecting full-bridge rectifier and as the H-Bridge inverter is very simple converter gate signal control. The SST provides a simpler and light weight solution and also economical for the low voltage AC applications.

## REFERENCES

- [1] E. I. Amoiralis, M. A. Tsilli, P. S. Georgilakis (2008, May), The state of the art in engineering methods for transformer design and optimization: a survey, *Journal of Optoelectronics and Advanced Materials* Vol. 10, pp. 1149-1158.
- [2] Er. Mamatha Sandhu, Dr. Tilak Thakur (2014, March), Issues, Challenges, Causes, Impacts and Utilization of Renewable Energy Sources Grid Integration, *International Journal of Engineering Research and Applications*, Vol. 4, Issue 3, pp. 636-643.
- [3] J. Arrillaga, M. J. Bollen, N. R. Watson, (2000, February). Power Quality Following Deregulation, *Proceedings of the IEEE*, Vol. 88, February 2000.
- [4] A.Elmoudi, M.Lehtonen, H. Nordman, Effect of Harmonics on Transformers Loss of life, *Proceedings of the IEEE International Symposium on Electrical Insulation*, 2006.
- [5] P. P. Barker, R. W. de Mello, Determining Impact of Distributed Generation on Power Systems: Part 1 Radial Distribution Systems, *Proceedings of Power Engineering Society Summer Meeting*, 2000, IEEE Vol. 3.
- [6] J. Setreus, L. Bertling, Introduction to HVDC Technology for Reliable Electrical Power Systems, *Proceedings of the 10th International Conference on Probabilistic Methods Applied to Power Systems*, 2008.
- [7] N. G. Hingorani, "FACTS Technology State of the Art, Current Challenges and the Future Prospects," *Power Engineering Society General Meeting*, IEEE 2007.
- [8] W. McMurray, The Thyristor Electronic Transformer: a Power Converter using a High-Frequency Link, *IEEE Transactions on Industry and General Applications*, Vol. 7, July/August 1971.
- [9] M. Kang, P. N. Enjeti, I. J. Pitel, Analysis and Design of Electronic Transformers for Electric Power Distribution System, *IEEE Transactions on Power Electronics*, Vol. 14, November 1999.
- [10] Y. Du, S. Baek, S. Bhattacharya, A. Q. Huang, High-voltage High frequency Transformer Design for a 7.2kV to 120V/240V 20kVA Solid State Transformer, *36th Annual Conference on IEEE Industrial Electronics Society*, 2010.

### Citation of this Article:

R.Yalini, S.Santhi, S.Velmurugan, M.G.Yogapriya, "AC-AC Solid State Transformer Based on Single Conversion Stage" Published in *International Research Journal of Innovations in Engineering and Technology - IRJIET*, Volume 6, Issue 6, pp 268-273, June 2022. Article DOI <https://doi.org/10.47001/IRJIET/2022.606041>

\*\*\*\*\*