

# An Optimum Design of Pressure Vessel by Using PV-ELITE Software

Chetan Patil

Department of Mechanical Engineering, Siddhant Collage of Engineering, Sudumbare , Pune-412109, India

**Abstract** - The safety factor of a pressure vessel is related to both the tensile stress and yield strength for material allowance. ASME code section VIII has fully covered these two on the construction code for pressure vessel. This code section addressed mandatory and non-mandatory appendixes requirement, specific prohibition, vessel materials, design, fabrication, examination, inspection, testing, certification, and pressure relief. Mechanical design of a horizontal pressure vessel based on this standard had been done incorporating PV ELITE software. Analyses were carried out on head, shell, nozzle and saddle. The input parameters are type of material, pressure, temperature, diameter, and corrosion allowance. Analysis performed the calculations of internal and external pressure, weight of the element, allowable stresses, vessel longitudinal stress check, nozzle check and saddle check.

**Keywords:** Pressure vessel, ASME section VIII division 1, PV- ELITE, Mechanical design.

## 1. Introduction

Pressure vessels are leak proof containers, as the name implies, their main purpose is to contain a given medium under pressure and temperature. Pressure vessels are commonly used in industry to carry both liquid and gases under required pressure and temperature limit. This pressure and temperature comes from an external source or by the application of heat from a direct or indirect source or any combination of them. They may be of any shape and size ranging beer canes, automobile tires or gas storage tank, to more sophisticated ones encountered in engineering applications. Pressure vessels; commonly have the cylindrical, spherical, ellipsoidal, conical or a combination of these shapes. However, some pressure vessels are named after the type of function they required to perform. For example, the distillation column is a vessel used in oil and petroleum refining process. The heat exchanger used in many types of industries to transfer heat from one fluid to another fluid, acted as same. Also, reactor is a vessel, which is used for chemical reaction of contained substance. The material comprising the vessel is subjected to pressure loading and hence stresses from all direction. The normal stresses resulting from this pressure

are functions of diameter of the elements under consideration, the shape of the pressure vessel as well as the applied pressure.



Fig. 1: Pressure vessel

## 1.1 Design Codes

Pressure vessels are always works under certain pressure and temperature along with contain sometime lethal substances which are hazardous for both human and environment. Considering this, safety implications and hazards arising from the operation of pressure vessels, there is an obvious need to standardize engineering and fabrication practices. To assure minimum safety standards, several design codes have prepared and developed. In Europe most widely National codes are:

GERMANY - AD MARKBLATTER, BRITISH – BS1500, BS 1515, ITALY – CCPA

In the United States and Canada, the most widely used Standards are the ASME boiler and pressure vessel code, published by American Society of Mechanical Engineers (ASME). ASME section VIII deals with the design for pressure vessels, materials specification, fabrication, opening and reinforcement, testing and marking, inspection and other mandatory or non mandatory appendixes. Section VIII contains three divisions, covering the different pressure ranges:

- Division 1: up to 3000 psi (200 bar)
- Division 2: up to 10000 psi (690 bar)
- Division 3: above 10000 psi (above 690 bar )

ASME section VIII, Division 1, deals with conventional pressure vessels means design by rule, while division 2, deals

with stringent alternative rules means design by analysis, and division 3 deals with design of Nuclear Equipment.

Vessels failure can be grouped into four major categories, which describe why a vessel failure occurs. Failures also grouped into types of failures, which describe how the failure occurs mean each failure contains its failure history, why and how it occurs. There are many reasons of vessels failure such as:

- Improper material selection, defected material.
- Incorrect design data, incorrect or inaccurate design method or process, inadequate shop testing.
- Improper fabrication process, poor quality control, insufficient fabrication process including welding, heat treatment and forming methods.



Fig. 2 Failure of pressure vessel during hydro Test

In order to meet a safe design, a designer must be familiar with the above mentioned failure and its causes. There have a few main factors to design safe pressure vessel. This study is focusing on analyzing the safety parameters for allowable working pressure. Allowable working pressures are calculated by using PV ELITE software which compile with the ASME section VIII, rules for construction pressure vessels. The objectives of the study is to design pressure vessel according to input data and analyze the safety parameters of each component for its allowable working pressure using; PV ELITE software.

II. DESIGN INPUT DATA

component	units	components	Units
Shell		Nozzle no.2	
Length	400 CM	NPS	300 MM
Internal dia	1500 MM	Schedule	80
Thickness	12 MM	Material	SA106B
Material	SA515GR70	Length	200 MM
C.A	3 MM		
Dished end (both side)		Nozzle no.3	
Type	Ellipsoidal	NPS	300 MM
Internal dia	1500 MM	Schedule	80
Material	SA515GR70	Material	SA106B
C.A	3 MM	Length	200 MM
Nozzle no.1		Saddle Width	250 MM
NPS	300 MM	Wear plate width	400 MM
Schedule	80	Contact angle	120 deg.
Material	SA106B	Wear plate thickness	12 MM
Length	200 MM		

Design Temp.		Design Pressure	
Internal	100 C	Internal	225 Psi
External	35 C	External	15 Psi

Table 1. Design Input Data

3. Results

Horizontal pressure vessel is drawn as per element input data and the icon for each element can be found easily. The input parameters for each element also type in the suitable bar as can be seen on screen. Once all the elements were connected, the pressure vessel would be as shown in figure. After completion of design in PV ELITE, design analysis has been carried out which shows results for each component as per input data. The results have shown safe and failure conditions as per ASME standard. Result analysis has been carried out in the form of equations, substitution and code references.

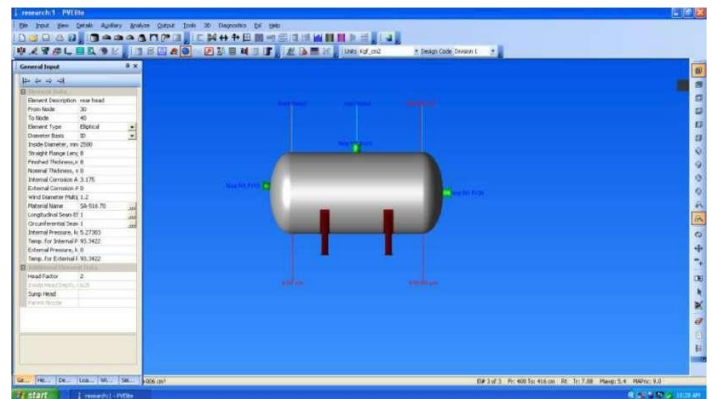

Figure 3 Mechanical Design of pressure vessel by PV ELITE

Internal Pressure Calculation Results:

ASME Code, Section VIII, Division 1, 2007

Elliptical Head (Both ends) SA-516 70, UCS-66 Curve. B at 100 C

Thickness Due to Internal Pressure [Tr]:

$$= (P * (D + 2 * CA) * K) / (2 * S * E - 0.2 * P) \text{ Appendix 1-4(c)} = (15.819 * (1500.0000 + 2 * 3.0000) * 1.00) / (2 * 1406.14 * 1.00 - 0.2 * 15.819) = 8.4808 + 3.0000 = 11.4808 \text{ mm}$$

Max. All. Working Pressure at Given Thickness [MAWP]:=

$$(2 * S * E * (T - Ca)) / (K * (D + 2 * Ca) + 0.2 * (T - Ca)) \text{ per Appendix 1-4(c)} = (2 * 1406.14 * 1.00 * (9.0000)) / (1.00 * (1500.0000 + 2 * 3.0000) + 0.2 * (9.0000)) = 16.786 \text{ kgf/cm}^2$$

Maximum Allowable Pressure, New and Cold [MAPNC]:=  
 $(2 \cdot S_a \cdot E \cdot T) / (K \cdot D + 0.2 \cdot T)$  per Appendix 1-4 (c) =  
 $(2 \cdot 1406.14 \cdot 1.00 \cdot 12.0000) / (1.00 \cdot 1500.0000 + 0.2 \cdot 12.0000) =$

22.462 kgf/cm<sup>2</sup>

Actual stress at given pressure and thickness [Sact]:

=  $(P \cdot (K \cdot (D + 2 \cdot CA) + 0.2 \cdot (T - CA)) / (2 \cdot E \cdot (T - CA))) = (15.819 \cdot (1.00 \cdot (1500.0000 + 2 \cdot 3.0000) + 0.2 \cdot (9.0000))) / (2$

$\cdot 1.00 \cdot (9.0000)) = 1325.111$  kgf/cm<sup>2</sup>

Percent Elongation per UCS-79  $(75 \cdot t_{nom} / R_f) \cdot (1 - R_f / R_o)$   
 3.501 %

Cylindrical Shell From 20 To 30 SA-516 70 , UCS-66 Curve.  
 B at 100 C

SHELL

Thickness Due to Internal Pressure [Tr]:

=  $(P \cdot (D/2 + CA)) / (S \cdot E - 0.6 \cdot P)$  per UG-27 (c)(1) =  
 $(15.819 \cdot (1500.0000/2 + 3.0000)) / (1406.14 \cdot 1.00 - 0.6 \cdot 15.819) =$   
 $8.5288 + 3.0000 = 11.5288$  mm

Max. All. Working Pressure at Given Thickness [MAWP]:=  
 $(S \cdot E \cdot (T - CA)) / ((D/2 + CA) + 0.6 \cdot (T - CA))$  per UG-27 (c)(1)

=  $(1406.14 \cdot 1.00 \cdot (9.0000)) / ((1500.0000/2 + 3.0000) + 0.6 \cdot 9.0000$

0) = 16.687 kgf/cm<sup>2</sup>

Maximum Allowable Pressure, New and Cold [MAPNC]:=  
 $(S_a \cdot E \cdot T) / (D/2 + 0.6 \cdot T)$  per UG-27 (c)(1)

=  $(1406.14 \cdot 1.00 \cdot 12.0000) / (1500.0000/2 + 0.6 \cdot 12.0000) =$

22.284 kgf/cm<sup>2</sup>

Actual stress at given pressure and thickness [Sact]:=  
 $(P \cdot ((D/2 + CA) + 0.6 \cdot (T - CA))) / (E \cdot (T - CA)) =$   
 $(15.819 \cdot ((1500.0000/2 + 3.0000) + 0.6 \cdot (9.0000))) / (1.00 \cdot (9.0000$

0)) = 1333.021 kgf/cm<sup>2</sup> Percent Elongation per UCS-79

$(50 \cdot t_{nom} / R_f) \cdot (1 - R_f / R_o) 0.794$  %

NOZZLE CALCULATION, Description: Noz N1,N2,N3

ASME Code, Section VIII, Division 1, 2007, UG-37 to UG-45  
 Actual Nozzle Inside Diameter Used in Calculation 288.950  
 mm.

Actual Nozzle Thickness Used in Calculation 17.450 mm  
 Nozzle input data check completed without errors.

Reqd thk per UG-37(a) of Cylindrical Shell, Tr [Int. Press] =  
 $(P \cdot (D/2 + CA)) / (S \cdot E - 0.6 \cdot P)$  per UG-27 (c)(1) =  
 $(15.82 \cdot (1500.0000/2 + 3.0000)) / (1406 \cdot 1.00 - 0.6 \cdot 15.82) =$   
 8.5288 mm

Reqd thk per UG-37(a) of Nozzle Wall, Trn [Int. Press] =  
 $(P \cdot (D/2 + CA)) / (S \cdot E - 0.6 \cdot P)$  per UG-27 (c)(1) =  
 $(15.82 \cdot (288.9504/2 + 3.0000)) / (1202 \cdot 1.00 - 0.6 \cdot 15.82) =$

1.9559 mm Req'd Nozzle thickness under External Pressure :  
 0.8627 mm

UG-40, Thickness and Diameter Limit Results : [Int. Press]  
 Effective material diameter limit, DI 589.9008 mm

Effective material thickness limit, no pad Tlnp 22.5000 mm  
 Effective material thickness limit, pad side Tlwp 22.5000 mm  
 Results of Nozzle Reinforcement Area Calculations:

AREA AVAILABLE, A1 to A5 Design External Mapnc Area  
 Required Ar 25.513 11.208 NA cm<sup>2</sup>

Area in Shell A1 1.370 4.380 NA cm<sup>2</sup>

Area in Nozzle Wall A2 4.807 5.228 NA cm<sup>2</sup> Area in Inward  
 Nozzle A3 0.000 0.000 NA cm<sup>2</sup> Area in Welds A4 2.216  
 2.216 NA cm<sup>2</sup>

Area in Pad A5 21.858 21.858 NA cm<sup>2</sup>

TOTAL AREA AVAILABLE Atot 30.251 33.681 NA cm<sup>2</sup>

The Internal Pressure Case Governs the Analysis.

Nozzle Angle Used in Area Calculations 0,90.00,180 degree.  
 The area available without a pad is Insufficient.

The area available with the given pad is Sufficient.

SELECTION OF POSSIBLE REINFORCING PADS:  
 Diameter Thickness

Based on given Pad Thickness: 466.7250 12.0000 mm Based  
 on given Pad Diameter: 506.0000 9.5250 mm Based on Shell  
 or Nozzle Thickness: 458.7875 12.7000 mm

Reinforcement Area Required for Nozzle [Ar]: =  
 $(D_{lr} \cdot Tr + 2 \cdot Thk \cdot Tr \cdot (1 - fr_1))$  UG-  
 37(c) =  $(294.9504 \cdot 8.5288 + 2 \cdot (17.4498 - 3.0000) \cdot 8.5288 \cdot (1 -$   
 $0.8550)) = 25.513$  cm<sup>2</sup>

Areas per UG-37.1 but with DL = Diameter Limit, DLR =  
 Corroded ID:

Area Available in Shell [A1]:= (DL-Dlr)\*(ES\*(T-Cas)-Tr)-2\*(Thk-Can)\*(ES\*(T-Cas)-Tr)\*(1-fr1)=(589.901-294.950)\*(1.00\*(12.0000-3.000)-8.529)-2\*(17.450-3.000)\*(1.00\*(12.0000-3.0000)-8.5288)\*(1-0.8550)  
=1.370cm<sup>2</sup>

Area Available in Nozzle Wall, no Pad [A2np]:= ( 2 \* min(Tlnp,ho) ) \* ( Thk - Can - Trn ) \* fr2 = ( 2 \* min(22.50,206.25 ) ) \* ( 17.45 - 3.00 - 1.96 ) \* 0.8550 = 4.807 cm<sup>2</sup>

Area Available in Nozzle Wall, with Pad [A2wp]:= ( 2 \* Tlwp)\*( Thk - Can - Trn ) \* fr2= ( 2 \* 22.5000 ) \* ( 17.4498 - 3.0000 - 1.9559 ) \* 0.8550 ) = 4.807 cm<sup>2</sup>

Area Available in Welds, no Pad [A4np]: = Wo<sup>2</sup> \* fr2 + ( Wi-Can/0.707 )<sup>2</sup> \* fr2= 9.5250<sup>2</sup> \* 0.8550 + ( 0.0000 )<sup>2</sup> \* 0.8550=0.776 cm<sup>2</sup>

Area Available in Welds, with Pad [A4wp]: = Wo<sup>2</sup>\*fr3+(Wi-Can/0.707)<sup>2</sup>\*Fr2+Wp<sup>2</sup>\*Fr4= 9.5250<sup>2</sup> \*0.86 + (0.0000 )<sup>2</sup> \*0.86 + 12.0000<sup>2</sup> \* 1.00 = 2.216 cm<sup>2</sup>

Area Available in Pad [A5]:= (min(Dp,DL)-(Nozzle OD))\*(min(Tp,Tlwp,Te))\*fr4= ( 506.0000 - 323.8500 ) \* 12.0000 \* 1.00= 21.858 cm<sup>2</sup>

UG-45 Minimum Nozzle Neck Thickness Requirement: [Int. Press.]

Wall Thickness per UG45(a), tra = 4.9559 mm Wall Thickness per UG16(b), tr16b = 4.5875 mm

Wall Thickness per UG45(b)(1), trb1 = 11.5288 mm Wall Thickness per UG45(b)(2), trb2 = 3.5650 mm

Wall Thickness per UG45(b)(3), trb3 = Max(trb1, trb2, tr16b) = 11.5288 mm

Std. Wall Pipe per UG45(b)(4), trb4 = 11.3344 mm

Wall Thickness per UG45(b), trb = Min(trb3, trb4) = 11.3344 mm

Final Required Thickness, tr45 = Max(tra, trb) = 11.3344 mm Available Nozzle Neck Thickness = .875 \* 17.4498 = 15.2686 mm --> OK

Results of saddle analyses.

Longitudinal Bending (+-) at Midspan= ( 0.25 \* Q \* L \* K.2 / ( pi \* R<sup>2</sup> \* ( Ts - Ca )) ) = ( 0.25 \* 5512 \* 412.70 \* 0.5234 ) / ( 3.141 \* 750.0000 \* 750.0000 \* ( 12.0000 - 0.0000 )) = 14.04 kgf/cm<sup>2</sup>

Longitudinal Bending (+-) at Saddle= ( 0.25 \* Q \* L \* K.1 / ( pi \* R<sup>2</sup> \* ( Ts - Ca )) ) = ( 0.25 \* 5512 \* 412.70 \* 0.3601 ) / ( 3.141 \* 750.0000 \* 750.0000 \* ( 12.0000 - 0.0000 )) = 9.66 kgf/cm

Tangential Shear in Shell near Saddle = Q \* K.4 \* (( L-H-2A ) / ( L+H )) / ( R\*(Ts-Ca) ) = 5512 \* 1.1707 \* (( 412.70 - 37.50 - 2 \* 42.58 ) / ( 412.70 + 37.50 )) / ( 750.0000 \* ( 12.0000 - 0.0000 )) = 46.20 kgf/cm<sup>2</sup>

Circumferential Stress at Horn of Saddle=- Q / ( 4 \* TEM \* ( SADWTH + 1.56 \* sqrt(R \* TCA) ) ) - 12 \* Q \* R \* K.7 / ( L \* TEB ) = -5512 / ( 4 \* 12.0000 \* ( 250.00 + 1.56 \* sqrt(750.0000 \* 12.0000 ) ) ) - 12.0 \* 5512 \* 62.50 \* 0.0184 / ( 412.7000 \* 144.0000 ) = -182.62 kgf/cm<sup>2</sup>

Circumferential Compression at Bottom of Shell = ( Q \* ( K.9 / ( TEM9 \* WPDWTH ) ) ) = ( 5512 \* ( 0.7603 / ( 24.0000 \* 400.000 ) ) ) = -43.66 kgf/cm<sup>2</sup>

#### 4. Discussion

Design of pressure vessel can be finished quickly by applying numerous calculations in software. The drawing process was simpler associated to the software. This study only investigated a part of parameters design. There are other parameters that are not considered such as thermal loads, wind loads, seismic load, transportation load, erection load and fabrication methods etc. however this insufficiency can be overcome by mastering software.

#### 5. Conclusion

Mechanical design of pressure vessel had been done using graphical based software. Drawing process was very easy and input can be entered in the same screen. The result fully complied with standard code and had been employed on practical design of pressure vessel.

Research can be explored to into account other parameters. Selection material referring to ASME, standard can also been developed. The behavior of pressure vessels in case of fluctuating load could be a challenging matter for future research

#### ACKNOWLEDGMENT

The author would like to thank following guises for his constant encouragement and able guidance. Prof.R.R.Kulkarni Prof.Kedar Bhagwat Siddhant Collage of Engineering, Sudumbare , Pune-412109.

## REFERENCES

- [1] ASME section VIII division 1, 2007.
- [2] Moss D.R. Pressure Vessel design manual Third edition.

### **Citation of this Article:**

Chetan Patil, "An Optimum Design of Pressure Vessel by Using PV-ELITE Software" in proceeding of International Conference of Recent Trends in Engineering & Technology ICRTET - 2023, Organized by SCOE, Sudumbare, Pune, India, Published in IRJIET, Volume 7, Special issue of ICRTET-2023, pp 75-79, June 2023.

\*\*\*\*\*