

Design of Microcontroller-Based Intelligent Street Light Controller

¹Mathias P.E., ²Obi M.C., ³Dimson I.C., ⁴Ani A.A.

^{1,3}Department of Electronic and Computer Engineering, Nnamdi Azikiwe University, Awka, Nigeria

²Department of Computer Engineering, Caritas University, Enugu, Nigeria

⁴Department of Computer Engineering, Madonna University of Nigeria, Akpugo Campus, Enugu State, Nigeria

Abstract - This paper, titled, “Design of Microcontroller-Based Intelligent Street Light Controller” uses AT89C52 microcontroller as its controlling device. The system switches on street lights at night and turns them off once darkness disappears in the morning. In this paper, an algorithm was developed for the system of operation, and the control program was written from the algorithm in Assembly language; though it could be written in any embedded system programming language like Embedded C++. The choice of any light-controlled sensor is possible but this research work uses Light Dependent Resistor (LDR) as its sensor for monitoring application. Real-time simulation was done using Proteus software so as to ascertain the workability of the design in real life. A prototype of the system was implemented and it tested ok.

Keywords: Microcontroller, street-light, real-time, algorithm, Proteus, sensor, comparator.

I. INTRODUCTION

1.1 Background of Study

Street lighting is one of the most essential services provided by government and communities, and it is very expensive. New technological advances can deliver up to 50% reductions in energy usage. The idea of designing a controller for street lights that automatically switches on the lights at nights and also puts off the lights in the morning when darkness has disappeared is of great concern to engineers working in community lighting field. Street Lighting can account for 10–38% of the total energy bill in typical cities worldwide [1]. Street lighting is a particularly critical concern for public authorities in developing countries because of its strategic importance for economic and social stability. This is because inefficient street lighting wastes significant financial resources every year, and poor lighting creates unsafe conditions. Energy efficient technologies and design mechanism can reduce cost of the street lighting drastically.

Manual control of street light is prone to errors and leads to energy wastages, and manually dimming during midnight is impracticable. Also, dynamically tracking the light level is

manually impracticable. The current trend is the introduction of automation and remote management solutions to control street lighting [2]. There are various numbers of control strategies and methods in controlling the street light system such as design and implementation of programmable based solar power saving system for street lights and automatic traffic controller, design and fabrication of automatic street light control system, automatic street light intensity control and road safety module using embedded system, automatic street light control system, intelligent street lighting system using GSM, and energy consumption saving solutions based on intelligent street lighting control system.

In this paper, the interest is to design a microcontroller-based system (controller) that automatically switches on a street lights at night and puts it off in the morning when darkness has disappeared. The system basically consists of a Light Dependent Resistor (LDR) as light sensor, power supply, relay and microcontroller.

The principle of operation of an LDR is that its resistance decreases when light intensity increases, and increases with decrease in light intensity (increase in darkness). The light sensor will detect darkness and the signal is used to activate the on/off switching by the microcontroller. The theoretical concept of the light sensor lies behind, which is used in this research as a darkness detector; and its resistance varies according to the amount of light falling on its surface.

The Relay is thus used to do the contact on/off switching [3]. The microcontroller used in this research is an Atmel product. The type is AT89C52 microcontroller. It handles all the processing of the signal from the sensor and controls all the switching applications.

This paper gives the best solution for electrical energy wastage. Also the manual operation of the lighting system is completely eliminated. It is very useful for commercial sign boards, advertising boards, street lights for automation lighting system. The system switches on the lights only at preprogrammed timings.

However, with the advancement of technology, particularly in the field of Microcontroller Engineering, all the activities in our day to day living have become a part of information, and microcontrollers are found at each and every application [4]. Thus since microcontroller acts as the brain of this research, a brief understanding of it will help to appreciate the work.

1.2 Microcontroller

A microcontroller is a single chip computer. It is a computer because it has all the component parts of a typical digital computer [5]. Those component parts are: the Central Processing Unit (CPU), Memory (ROM and RAM) and Input/output units. The difference between a microprocessor and microcontroller is that a microprocessor is only a processor without an internal memory, but can access external memory; while a microcontroller contains a processor as well as an inbuilt (internal) memory.

There are different types of microcontrollers from different manufacturers. The common ones are PIC microcontroller, Motorola (68HC05) Microcontroller, ATMEL Microcontroller, Intel Microcontroller, etc. In this paper, ATMEL microcontroller was used.

Different types of ATMEL microcontrollers exist in markets. The type used for any design is determined by program size and its availability in the market. Some examples of ATMEL microcontrollers are: AT87C51, AT89C51, AT89C52, AT89C55, AT89C2051 etc. The difference between these microcontrollers is their memory size and sometimes their port configuration, for instance, AT89C51 or simply AT8955 has 20kb of ROM. The AT89C2051 has 2 ports with 4Kb of ROM, while others listed above have 4 ports each. Therefore, it can be said that AT89C2051 is mainly used for small projects because of its number of ports [6].

Memory size may not be a hindrance in choosing any microcontroller for designs. This is true because one can simply use AT89C52 and if a project needs modification that requires large ROM memory space, one can just buy a program memory i.e. Read Only Memory (ROM) and store those programs. This additional ROM must be connected to the microcontroller through transparent latch (74373) or D-flip flop (74374) [7].

1.2.1 The AT89C52 Microcontroller

This type of microcontroller (AT89C52) was used for this research work. The standard features are:

- 8 KB of internal ROM (EEPROM)

- 256 bytes of RAM (SRAM)
- 32 I/O pins
- 8 special pins
- Two 8/16 bit timers
- Four programmable I/O Ports (P0, P1, P2, and P3)
- Multiple internal and external interrupt sources
- Programmable serial port
- VCC of 5Volts
- On chip oscillator and clock circuitry

II. LITERATURE SURVEY

2.1 Review of Past Related Works

Many researchers have done several works on the control of street lights. But in the general control systems, the first significant work in automatic control was James Watt's centrifugal governor for the speed control of a steam engine in the eighteen century [8]. Other significant works in the early stages of development of control theory were due to Minorsky, Hazen, and Nyquist, among others.

In 1934, Hazen, who introduced the term "servomechanism" for position control systems, discussed the design of relay servomechanisms capable of closely following a changing input. During the decade of the 1940s, frequency-response methods (especially the Bode diagram methods due to Bode) made it possible for engineers to design linear closed loop control systems that satisfied performance requirements. From the end of the 1940s to the early 1950s, the root-locus method due to Evans was fully developed.

As modern plant with many inputs and outputs became more and more complex, the description of a modern control system required a large number of equations. Classical control theory, which deals with only single-input-single-output systems, became powerless for multiple-input-multiple-output systems. Since about 1960, because the availability of digital computers made possible time-domain analysis and synthesis using state variables techniques have been developed to cope with the increased complexity of modern plants and the stringent requirements on accuracy, weight, and cost in military, space, and industrial applications.

During the years from 1960 to 1980, optimal controls of both deterministic and stochastic systems, as well as adaptive and learning control of complex systems, were fully investigated [9]. From 1980 to the present, developments in modern control theory centered on robust control, and associated topics.

Now that digital computers have become cheaper and more compact, they are used as integral parts of control systems. Recent application of modern control theory also

includes such non-engineering systems as biomedical, economic, and socioeconomic systems.

The old method of street light control was the use of manual method [10]. This involves the operation of switch gears in putting street lights ON or OFF. Thus the old method has since been thrown out based on the following. Firstly, it is a manual method therefore it is not reliable. Secondly, due to constant attendance to the switch gears, they easily develop faults and their repairs can take a number of days which make the street lights not to be working within that period. Thirdly, operator's irregular attendance to duty makes the efficiency of this manual method poor. Fourthly, the design of the manual method is complex, compared to the microcontroller-based design. Large circuitry is involved and this makes troubleshooting of fault very difficult. Fifthly, the manual method makes use of many discrete components unlike the microcontroller-based method that involves program. And the use of many discrete components causes not good because any component can develop fault at an unexpected time thereby affecting the overall system's efficiency.

With the introduction of a single chip computers called microcontrollers, automatic monitoring and control of processes is made easy; but the chip must be programmed for such task using any suitable language, based on that microcontroller's instruction set. In Rogers [11], there was a highlight on the design of a new intelligent street light control system which does not only achieve energy-saving power but also extends the service life of lighting equipment.

There is a recent innovation in street light control design with the introduction of Telematics Wireless's solution for Smart Lighting which enables utilities and maintenance companies to benefit from an improved level of cost-effective, reliable and timely service, by controlling and managing street light operations. It helps provide a safer, urban environment for people, and reduces carbon footprints, contributing to environmental sustainability.

The Smart Street Lighting Controlling system establishes a wireless network between all participating light poles and provides the operator with a web-accessed efficient, automatic or manual, control of the light pole's operation. The system may also apply to a smart lighting system, where the light poles already have, or can have, a wired connection.

III. METHODOLOGY AND SYSTEM DESIGN

3.1 Methodology

In the course of development of this paper, several steps were taken and they are enumerated below:

- a) Understanding the problem and gathering information.
- b) Choosing the appropriate method that will be used in solving the problem based on the information gathered. From the information gathered, it is found out that there are three distinct way of designing the system in view, these includes: on/off control, proportional control and proportion with integral and derivative (PID) control. Based on the nature of system that is to be designed which involves the switching of a heater and a fan, the use of the on/off control for the design was chosen.
- c) Selection of design tools and sourcing of components.
- d) Hardware construction and testing.
- e) Software design and testing.
- f) Software and hardware integration and final testing.

3.2 The Existing System

The old method of street light control was the use of manual method. It involves the operation of switch-gears in putting street lights ON or OFF. In this method, an operator must always be present in the night and early in the morning to put the street lights OFF and ON respectively. Except the advantage of offering job opportunity to people as switch-gear operators, the numerous disadvantages of using this manual method make the system inappropriate, and hence no more in use.

A later improvement of the manual method is the design of street light control using IC 555 timer. The use of IC 555 timer envelops the use of transistor as a switch. It has many disadvantages too.

3.3 Problems of the Existing System

The old method of street light control has since been thrown out based on the following points. Firstly, it is a manual method, therefore it is not reliable. Secondly, due to the constant attendance to the switch gears, they easily develop faults and their repairs can take a number of days which make the street lights not to be working at that period. Thirdly, operator's irregular attendance to duty makes the efficiency of this manual method poor. Fourthly, the design of the manual method is complex, compared to the microcontroller-based design. Large circuitry is involved and this makes troubleshooting of fault very difficult. Fifthly, the manual method makes use of many discrete components unlike the microcontroller-based method that involves program. And the use of many discrete components is not good because any component can develop fault at an unexpected time thereby affecting the overall system's efficiency.

3.4 Block Diagram of the Proposed System

The block diagram of the proposed intelligent street light controller is shown in figure 1.

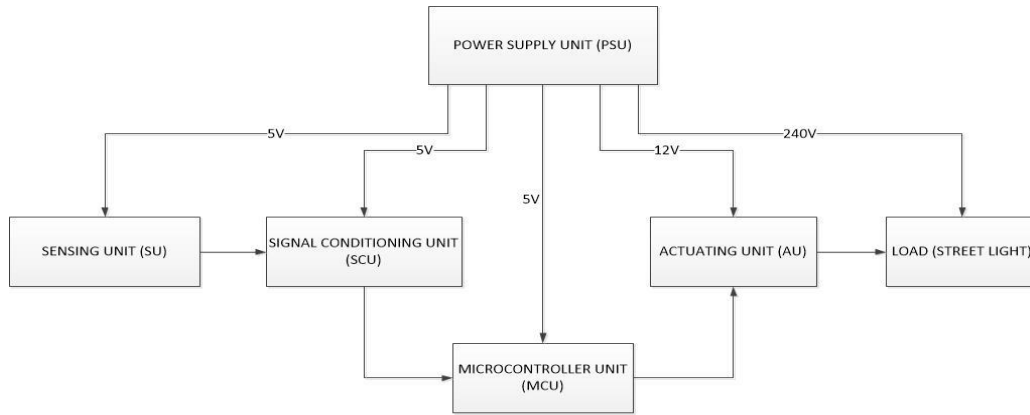

Figure1: Block Diagram of the Proposed Intelligent Street Light Controller

The block diagram of the intelligent street light controller consists of: the Power Supply unit(PSU), the sensing unit (SU), the signal conditioning unit (SCU), the actuator unit (AU), the microcontroller unit (MU) and the load (bulbs).

3.4.1 The Power Supply Unit

The power unit supplies power to the whole circuit, it supplies both the 12V which drives the relays and the 5V needed by the microcontroller and other components. This module is made up of a transformer, a bridge rectifier, an electrolytic capacitor, and two regulators.

i) The transformer: The transformer used is a simple step-down transformer with secondary windings of 220V/50Hz, a primary winding of 12V and current of 1000mA (which is greater than the current requirement of the circuit).

The primary and the secondary windings are related by the equation (1):

$$\frac{V_p}{V_s} = \frac{I_s}{I_p} = \frac{N_p}{N_s} \dots\dots\dots (1)$$

Where, V_p , I_s and N_p = primary voltage, secondary current and number of turns of the primary coil; V_s , I_p and N_s = secondary voltage, primary current and number of turns in the secondary coil.

Since the maximum required voltage is 12V and the mains voltage supply is 220V, we have:

$$\frac{220}{12} = \frac{N_p}{N_s} = \frac{55}{3} \dots\dots\dots (2)$$

Hence the ratio of the primary to the secondary coil of the transformer used is 55:3.

ii) The bridge rectifier: A full wave bridge rectifier is used with a step-down transformer to convert the AC voltage coming into the circuit into a DC voltage.

There are basically four diodes used. D1 and D2 are forward biased and conduct current when the input cycle is positive. The positive half of the input cycle is made from the voltage across the load resistance, D3 and D4 are reversed biased. Throughout the negative input cycle, D3 and D4 are forward biased and conduct current. A voltage is again made across the load resistance in the same direction as during the positive half-cycle.

iii) The filter: A capacitor is positioned in parallel with the output of the bridge rectifier to minimize the ripples in the rectified voltage, which will create a clean DC voltage.

The formula r in equation (3) was used to calculate the capacitance value for the filtering capacitor:

$$C = \frac{I}{2V_{pp} f} \dots\dots\dots(3)$$

Where:

- V_{pp} is the peak-to-peak ripple voltage
- I is the current in the circuit
- f is the frequency of the ac power
- C is the capacitance.

From the transformer used,

$$V_{pp} = \sqrt{2} \times 11.5 = 16.26V;$$

$$I = 0.5A; f = 50Hz.$$

$$\text{Hence, } C = \frac{0.5}{2 \times 16.26 \times 50} = 307.44 \mu F$$

The minimum capacitance that the calculations give when using the formula is not used, in practice a larger value is used so that the capacitor can charge more (1000µF is used).

iv) Regulators: Voltage regulators (ICs) called 7805 and 7812 are used to produce the 5V and 12V DC voltages needed for the microcontroller and the relay circuit. The output from the filter circuit is 15V when tested, and after regulation we have 5V and 12V. The final circuit for the power module is shown in figure 2.

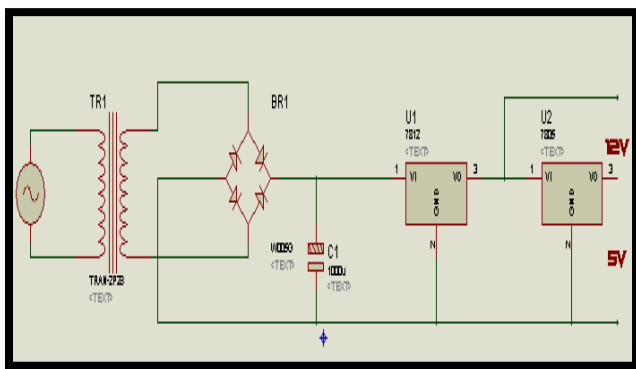

Figure 2: The Sub-circuit diagram of the Power Unit

3.4.2 Sensing Unit

The sensing unit in this work is the Light Dependent Resistors (LDR), which is a light sensor. This Light sensor has the characteristics that when an object blocks the sensor or casts a shadow on the sensor, the presence is detected by the change in resistivity of the sensor. This is because, if radiation falls upon this semiconductor, its conductivity increases because the radiation breaks the covalent bonds in the conductor thereby increasing the hole-electron pairs and decreasing the resistance of the conductor. It is one of the simplest sensors.

One peculiar feature of LDR sensor is that its resistance increases as darkness increases and reduces as the light intensity increases.

3.4.3 Signal Conditioning Unit

The content of this signal conditioning unit is a comparator, which is LM324. This is an integrated circuit (IC) containing four comparators embedded in the IC. A comparator is a circuit that compares two input voltages and produces an output in either of two states, including the greater than or less than relationship of the inputs. A comparator switches to one state when the input reaches the upper trigger point. It switches back to the other state when

input falls below a lower trigger point. So, if the positive input is higher than the negative input, the output goes to a HIGH or 1 state and, if the negative or inverting input is higher than non-inverting or positive input, a low or 0 state is produced. The pin configuration of LM324 is shown in figure 3.

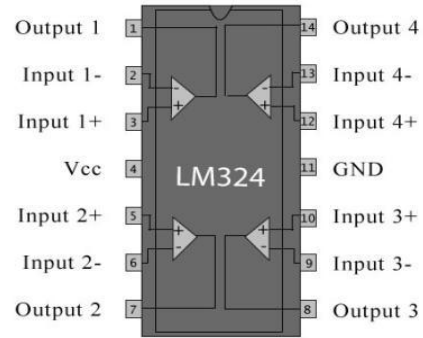

Figure 3: Pin Configuration of LM324

3.4.4 Microcontroller Unit

The AT89C52 microcontroller was chosen as the controller for the project since it offers various functions that are applicable to the system to be developed; also, it is the most available microcontroller in the market. AT89C52 has a power circuit, reset circuit, and clock circuit.

a) Power circuit: The power circuit provides power for the microcontroller. The AT89C52 uses a voltage of 5V DC and this is supplied by the power module. The power circuit of the microcontroller simply involves connecting pin-40 of the controller to 5V supply and pin-20 to ground.

b) The reset circuit: This circuit resets the device when a high is on the reset pin (pin-9) for two machine cycles.

c) Clock circuit: This provides timing for the microcontroller. The AT89C52 can generate its own internal clock signal. In order to generate clock for the microcontroller, the output of the clock circuit must be connected to XTAL1 (pin-18) and XTAL2 (pin-19). An oscillator and two capacitors are required for the connection. If a crystal oscillator is used, then the capacitors required will be 30pF±10 and if a resonator is used, the capacitors will be 40pF±10.

This senses the change in light intensity and varies the voltage accordingly.

SCU: This compares the input voltages and conditions the output.

AU: This ensures the switching of the transistor and the relay.

LOAD: This refers to the electric bulb to be powered or any other electrical system to be controlled.

MCU: this is the processing unit that contains the programming for the system.

3.4.5 The Actuator Unit

The actuator unit, shown in figure 4, comprises of a transistor (BC337), a relay (12V /400Ω coil), a diode (1N4148) and resistor R1. The transistor is controlled by the microcontroller in such a manner that when a high is applied to the base, a voltage drop of 5V developed across R1 which will cause a minimum current of 1mA (which will produce a current of 100mA at the collector circuit since BC337 has a gain of 100 enough to drive the relay which requires a minimum of 30mA ($\frac{12V}{400\Omega}$)) to flow through the base when a high is on that pin.

$$R1 = \frac{Vc}{i} \dots\dots\dots (4)$$

$$= \frac{5}{1mA} = 5000\Omega$$

Current flowing through the relay creates a magnetic field which collapses suddenly when switched off thus inducing a high voltage across the transistor which may damage its IC. To prevent this, the diode D1 is connected across the coil in such a manner that the high voltage will drive a brief current through the coil and the diode itself so that the magnetic field dies away quickly rather than instantly and this prevents high voltage from developing across T1 when the relay switches off.

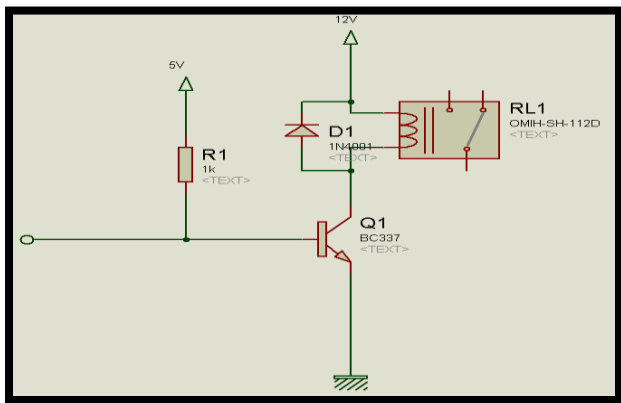

Figure 4: The Actuator Circuit

3.4.6 Relays

A relay is an electrically operated switch. Current flowing through the coil of the relay creates a magnetic field which attracts a lever and changes the switch contacts. The coil current can be ON or OFF so relays have two switch positions and most have double throw (changeover) switch contacts. Relays allow one circuit to switch a second circuit

which can be completely separate from the first. For example a low voltage battery circuit can use a relay to switch a 230V AC mains circuit. There is no electrical connection inside the relay between the two circuits; the link is magnetic and mechanical. A typical picture of a relay is shown in figure 5.



Figure 5: A Typical Picture of a Relay

The coil of a relay passes a relatively large current, typically 30mA for a 12V relay, but it can be as much as 100mA for relays designed to operate from lower voltage. Most ICs (chips) cannot provide this current and an "IC" transistor is usually used to amplify the small IC current to the larger value required for the relay coil. The maximum output current for the popular 555 timer IC is 200mA so these devices can supply relay coils directly without amplification.

Relay Switch Connections

The relay's switch connections are usually labeled COM, NC and NO:

COM = Common, always connect to this; it is the moving part of the switch.

NC = Normally Closed, COM is connected to this when the relay coil is off.

NO = Normally Open, COM is connected to this when the relay coil is on.

Connect to COM and NO if you want the switched circuit to be on when the relay coil is on. Connect to COM and NC if you want the switched circuit to be on when the relay coil is off.

Advantages of Relays:

- Relays can switch AC and DC, transistors can only switch DC.
- Relays are often a better choice for switching large currents (> 5A).
- Relays can switch many contacts at once.
- Relays can switch higher voltages than standard transistors.

Disadvantages of Relays:

- Relays use more power due to the current flowing through their coil.

IV. SYSTEM ANALYSIS

4.1 System Description

The system is an automated street light controller that automatically turns ON the street light during the day and automatically turns it OFF during the night. The system is able to detect a quick flash of light but does not turn the street light off immediately. The street light is turned ON or OFF only when the appropriate condition persists for more than five (5) seconds. With the use of a microcontroller (AT8952) and the relay, appropriate controls are effected to the different components for the control and switching operation.

4.2 Component descriptions

A system is constructed with certain components, and every component has its own function. When integrated to each other, the components form the whole system. Microcontroller systems usually have an input, controller and the output. In this intelligent street light controller, the input is a light sensor, the controller is a microcontroller and the output is a bulb driven by a transistor and isolated from the main circuit by a relay.

4.3 Software design

Without the accompanying program that is burnt into the microcontroller, the hardware design is as good as useless. In the development of a software program the following steps are necessary:

- Design conception
- Planning
- Selection of tools
- Coding

Proper planning is required, if not, the software program is seldom successful. The first step in the development is to set out some form of blueprint based on the information gathered on the required system that is to be developed. As a guideline, a flowchart is used to represent the system's functionality. The flow chart of the intelligent street light controller is discussed in section 4.4. The flowchart makes coding simpler since it elaborates the interaction between the various functional elements of the systems as well as the objects.

4.4 Program Flowchart

The figure 6 shows the program flowchart of the design. It was based on the program flowchart that the control program was developed.

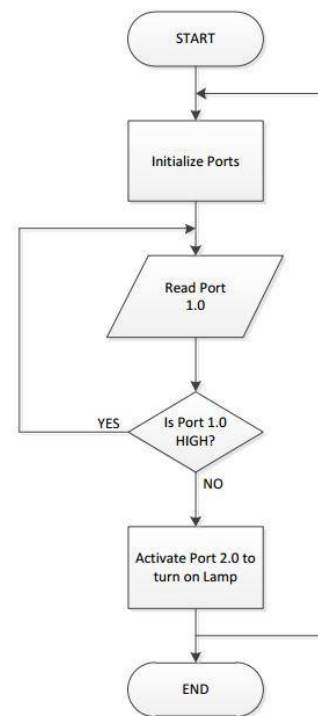

Figure 6: Program Flowchart of the Design

The Control Program

```

org 00h
Start:
mov p1, #11111111b
mov p2, #00000000b
check: jb p1.0, check
mov p2,#11111111b
call lapse
mov p2,#00000000b
jmp Start
lapse:
PET:mov R1,#120
mov R2,#0
mov R3,#38
MEG:djnz R1,MEG
djnz R2,MEG
djnz R3,MEG
ret
end
  
```

4.5 Analysis of the System

Power is supplied to the circuit from the PSU (Power Supply Unit). This PSU has a transformer and a rectifier for stepping down the 240V A.C. mains to a 12V A.C. and converting this voltage into a 12V D.C. respectively. On entering the circuit, the 12V D.C. is fed to two voltage regulators; a 7812 and 7805 of which the former supplies the relay and the latter supplies the rest of the circuitry.

The work basically applies the working principle of a light dependent resistor (LDR) for its operation. The principle is thus: As the intensity of light increases, the resistance decreases, and voltage increases. Also, as the intensity of light decreases, the resistance increases, and voltage decreases. With this in mind, as light hits the LDR (daytime scenario), the resistance is decreased and voltage increases. When this happens, a HIGH is sent to the output of the OP-AMP, of which is inverted into a LOW before entering the microcontroller. On entering the microcontroller, the controller performs some check operation on the input received. The microcontroller will only switch the light ON if it receives a HIGH. Now, as darkness hits the LDR (night scenario), the resistance is increased and voltage is decreased. When this happens, a LOW is sent to the output of the OP-AMP, which gets inverted to a HIGH. As this HIGH input hits the microcontroller, it sends the control signal to put ON at the port on which the light is connected to. The OP-AMP compares the input voltage signals at the LDR and potentiometer. When the voltage of the former is high, the light remains OFF, but when it is low, the light remains ON.

4.6 Precautions Taken During Soldering of components on Veroboard

- The bit of soldering iron was kept clean with the help of a file from time to time.
- The solder wires are of smaller thickness.
- Extra solder was not be used because it may cause a short circuit in the conductive path.
- The components were not overheated during soldering.
- The leads of the components were cleaned before soldering with a sand paper.
- The bit the soldering iron is cleaned properly before soldering.
- The joint was heated up to the required temperature at which the solder melts and comes around the joint. The joint was not disturbed before the solder set.

V. CONCLUSION

The aim of this research has been achieved, and that is the design and implementation of a microcontroller-based system (controller) that automatically switches on a street light and puts it off in the morning when darkness has disappeared. The system basically consists of a Light Dependent Resistor (LDR) as light sensor, power supply, relay and microcontroller.

The principle of operation of an LDR is that its resistance decreases when light intensity increases, and increases with decrease in light intensity (increase in darkness). The light sensor will detect darkness and the signal is used to activate the on/off switching by the microcontroller. The theoretical

concept of the light sensor lies behind, which is used in this work as a darkness detector; and its resistance varies according to the amount of light falling on its surface.

The Relay is thus used to do the contact on/off switching.

The microcontroller used in this research is an Atmel product. The type is AT89C52 microcontroller. It handles all the processing of the signal from the sensor and controls the switching application.

This research gives the best solution for electrical energy wastage. Also the manual operation of the street lighting system is completely eliminated.

It is very useful for commercial sign boards, advertising boards, street lights for automation lighting system. The system switches on the lights only at preprogrammed timings.

REFERENCES

- [1] F.L Lewis, "Applied optimal control and estimation", Prentice Hall, USA, 2012.
- [2] Timesys publication, "The concise book of real time systems" Timesys Corporation, Pittsburgh, 2012.
- [3] John G. Webster et al, "The measurement, instrumentation and sensors handbook" CRC press LLC, 2013. Pg 939, 951-968.
- [4] Muhammad Ali Mazidi, Janice Gillispie Mazidi, Rolin D. McKinlay, "The 8051 Microcontroller and Embedded Systems", Prentice Hall, New Jersey USA, 2009.
- [5] ATMEL corporation, "ATMEL 8-BIT MICROCONTROLLER WITH 8K FLASH", AT89C52 datasheet, source: <http://www.atmel.com>
- [6] Edward Hughes, "Electrical and Electronics Technology", Pearson education Ltd, India, 22011. PP 634.
- [7] Millman – Halkias, "Integrated Electronics", McGraw – Hills Kogakusha, 1972. Pg 112-114.
- [8] Ogata Katsuhiko, "Modern Control Engineering", Fourth Edition, Prentice Hall of India, Private Limited, New Delhi, 2007, Pp 1-2.

