

The Effect of Smart Grid Technology for Future Energy Sustainability in Nigeria's Power System

¹Eleje E.N., ²Ejimofor I.A., ³Ani S.E.

^{1,3}Department of Electrical and Electronic Engineering, Madonna University, Nigeria

²Department of Computer Engineering, Madonna University, Nigeria

Authors E-mail: nceleje@gmail.com, ihekeremmaejimofor6@gmail.com, sanizee@yahoo.com

Abstract - The effectiveness and efficiency of Nigeria's power system are impacted by some inherent disadvantages of interconnected power systems, despite their benefits in providing mutual support during emergencies and gaining the financial advantage of new large-scale generation and transmission facilities. Practical experience with well-developed systems indicates that these disadvantages are quite noticeable. When a huge, linked system reaches a virtual elastic limit, it must collapse to preserve stability and dependability. The smart grid system is the answer. The idea, characteristics, and suitability of smart grids for developing nations like Nigeria are covered in this paper. New developments in Nigeria's electricity sector are also emphasized and spoken about.

Keywords: Interconnected system, stability, smart-grid, reliability, elastic limit.

I. INTRODUCTION

The power grid was established in 1896 and was partially based on Nikola Tesla's 1888 design. However, more than 50 years ago, electricity networks have not been able to keep up with contemporary challenges like security threats, the employment and distribution of national power, the high demand for high-quality power, and so forth. As a result, the idea for the smart grid emerged, and its name has been in use since 2005, when it was mentioned in the paper "Toward a Smart Grid" [2]. There have been past uses of the phrase, maybe going back to 1998.

"A modern electric system" is how the Ontario smart grid forum defines the smart grid. It enhances the electrical system's dependability, security, predictability, efficiency, safety and load management through the use of computers, automation, sensors, and communication. By providing possibilities for customers to regulate their power use and react to changes in electricity prices by modifying their use, it gives them more choices. Electric car charging is supported and a variety of distributed energy sources are included in a smart grid. To put it briefly, it makes the electrical network system operation to improve for the benefit of customers and

the environment by bringing all components of the electricity system like production, distribution, and consumption—closer together.

"An automated, widely distributed energy delivery network, the smart grid will be characterized by a two-way flow of electricity and information and will be capable of monitoring everything from power plants to consumer preferences to individual appliances," according to the definition of a smart grid put forth by the U.S. Department of Energy (DOE). In order to provide real-time information and facilitate the almost immediate balance of supply and demand at the device level, it integrates the advantages of distributed computing and communication into the grid.

According to the Canadian Electricity Association, a smart grid is a collection of information-based applications that are made possible by the electricity grid's increased automation and the underlying automation itself. These technologies combine various supply and load behaviors and actions through distributed communication capabilities to provide secure, affordable, and sustainable power sources.

The electric network, digital control appliances, and intelligent monitoring system that make up a smart-grid are all capable of delivering electricity from producers to consumers, controlling energy flow, lowering losses, and improving the dependability and controllability of the electric network's performance [15].

Applications for smart grid technology are found all around the world. In industrialized nations, smart grid technology may be used to expand, digitalize or improve existing grid systems while also creating chances for the implementation of fresh, creative ideas. Smart-grid technologies are crucial for developing and emerging nations to prevent being locked into outmoded energy infrastructure, draw in new investment, and build flexible and efficient grid systems that can handle a variety of power sources and rising electricity demand. Technologies used in smart grids are already making important contributions to electricity grid operation in many countries. Case studies from countries like Netherland, Jamaica, Denmark, Singapore and United States,

showed that, it was successful, using the combinations of smart-grid technologies with integration of renewable energy.

Self-healing, active interaction of consumer, energy generation and storage options, penetration into new markets, stability, and higher-quality power offers are all features of the smart grid. The contrast between the present (current) and smart grids is summed up in Table 1. Additional benefits of a smart grid include knowledge gain, efficiency, control, reliability, and communication, which increase the power grid's dependability for a sufficient supply of electricity. [18]

II. LITERATURE REVIEW

Previously, attempts made to use electronic control, metering, and monitoring in power system like SCADA gave rise to smart-grid technology. The 1990s metering infrastructure had meters that could record the amount of power used at various periods. Automatic meter reading, which became advanced in the 1980s, was utilized to check loads (load management) from major clients. In addition to providing real-time monitoring through continuous communications, smart meters can be a gateway to demand response-aware gadgets and "smart sockets" in a home. The first demand side management technologies were dynamic demand active devices that monitor variations in the power supply frequency to passively detect the load on the grid. Appliances like heaters, freezers, and air conditioners (residential and commercial) modified their duty cycle to avoid activation during times the grid was suffering a peak condition.

One of the oldest and largest examples of smart grid is the Italian System established by Enel S.P.A. of Italy [15]. When the Telegestore project was finished in 2005, it was quite unique in the utility industry since the business created its own software for the system and produced its own meters, acting as a self-contained system integrator. At a 2.1 billion euro project cost, the Telegestore project is greatly considered the first application of smart grid technology in homes, generating 500 million euros in yearly savings.

Many applications, methods, and smart grid technological advancement systems have been established or are in the process of being developed, according to [14]. The main issue, is that there is currently no generally recognized standards for the smart grid system as a whole. This makes it difficult to integrate cutting-edge applications like smart devices, smart meters, and renewable energy sources, which hinders the interoperability of these components. An important precondition for the implementation of smart grid system is the adoption of interoperability standards for the whole system.

The objectives of standardization initiatives of smart grid include seamless interoperability, strong information security, data management, improved safety of new goods and systems, communication interchange and set of protocols system. Several initiatives are made regionally and nationally to achieve this goal. For instance, the strategic energy technology plan of the European Union Technology Platform organization focuses on developing a smart electricity system over the next thirty years. The Ontario Energy Board in Canada has also committed to completing the installation of smart meters. Other initiatives include the Third Generation Partnership Project, NIST, the American National Standards Institute (ANSI), the International Electro Technical Commission (IEC), the International Organization for Standardization (ISO), and the International Telecommunication Union (ITU).

Many people believe that smart grid technology just consists of updating the antiquated system, according to Stefano Galli (2012). That is indeed required in many nations, but smart grid technology entails much more. In essence, the electricity grid is an ideal just-in-time system, and this must be understood in order to comprehend smart grid. Delivery, consumption, and generation must all occur simultaneously, and the system must be balanced always. In the situation of time-varying renewable generating technologies, storage technologies, and varying load behavior brought on by the launch of new, interactive demand-side management (DSM) and demand response (DR) programs, the smart grid must maintain this equilibrium.

III. SMART GRID TECHNOLOGY

With the National grid located at Oshogbo, hundreds of kilometers away from many consumers, the traditional electrical power grid (shown in Fig. 1) is unidirectional in nature, with electricity flowing from power generation facilities to end users. This system has served for decades. However, government deregulation and policies that have been plagued by a number of technical, environmental, and financial problems have affected generation, transmission, and distribution. Because there are already a lot of overhead conductors and subterranean cables in use, which are terribly insufficient for wheeling the electricity, the network has unique overload difficulties that lead to large technical losses.

A distributed automation system, advanced metering infrastructure, and a sensible penetration of distributed resources are all part of a smart distribution grid (AMI). Infrastructure to enable automation, distribution response management, and sophisticated metering and communications are also included. Numerous operational and business software applications and information systems are also involved in the deployment [9].

A combination of technological, social, political, environmental, and economic forces have led to the development of the smart grid idea. Perhaps the component of power supply infrastructures where smart grid technologies are most likely to make an influence is distribution systems [1].

It is anticipated that the smart grid would completely transform the current conventional power system (shown in fig. 1) by enabling two-way communication to enhance the generation, transmission, and distribution of electrical power's efficiency, dependability, economy, and sustainability [9]. However, before the smart grid's full benefits can be realized, issues with administration and communication must be resolved. Additionally, the design of smart devices takes into account how to guarantee dependability and security, optimize the use of network resources and available power, and provide self-healing capabilities are considered in the design of smart grid is shown in figure 2.

Some people think that there is going to be a significant change in electric power. The need for energy conservation and worries about climate change, together with the convergence of information and power delivery technologies, are the main drivers of this development. The electric distribution grid is one area where the changes are most noticeable. Digital instrumentation, two-way communications, automation, and "blind" and manual operations and electromechanical components from the previous century are being replaced by a "Smart Grid" [9].

the smart grid system architecture depicted in figure 2 are converters, which allow for the application of ICT since they are memory-based and interactive in nature. In order to facilitate ICT use, loads are also designed to be interactive. Demand and supply are effectively balanced, and energy output is maximized, through the employment of a demand side management system that is entirely computer driven.

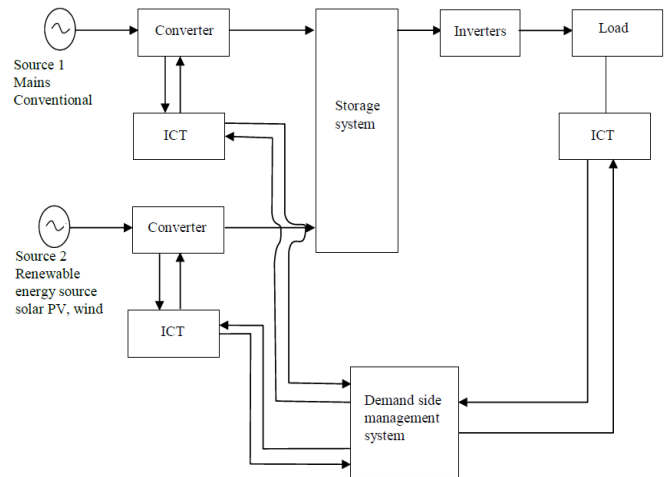

Figure 2: Block diagram of Smart Grid System

3.1 Characteristics of Smart Grid

- **Reliability:** Because of the growing need for electricity, the sluggish reaction time of mechanical switches, the absence of autonomous analytics, the rise in blackouts, and the decline in income. But today's smart grid technology may address these issues by enhancing fault detection, intelligent metering, and network self-healing without the need for operator involvement.
- **Flexibility in network topology:** Smart grids stimulate the development and distribution of renewable energy through the use of bidirectional energy flows that provide dispersed generation from sources like photovoltaic cells, fuel cell batteries, wind turbines, pumped hydro, etc.
- **Efficiency:** Demand side management using the smart grid to turn off air conditioners during brief increases in electricity prices results in increased use of generators and redundancy in transmission and distribution networks, which in turn lowers power costs.
- **Load adjustment:** Lowering some loads in to support a crucial increase to preserve equilibrium or give the generator time to start up. It improves load management on power infrastructure, such as bus bars and transformers, more effectively.
- **Peak curtailment/leveling and time of use pricing:** Employing smart devices which utility companies can monitor and manage in residences and commercial spaces. It forces utility or power providers to keep tabs on and monitor their equipment.

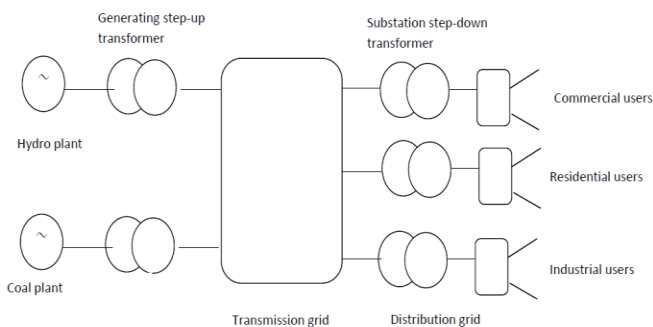

Figure 1: An Example of the Traditional Power Grid

A potential answer to the long-term evolution of the industry is the design seen in figure 2. Because renewable energy sources like wind, solar, and other energy sources are cleaner for the environment than the fossil fuels utilized in many bulk electric power generating facilities, they may thus be added to the present electric grid system in order to improve it. Additionally, in order to improve dependability and lower transmission loss, each of these additional power producing units may be dispersed across the load centers and kept relatively small. This adds even more flexibility to the system, but it also makes it more complex. The components of

- **Sustainability:** Smart grid allows many feed-in points i.e solar, wind, etc into the system without disturbing the entire system architecture.
- **Market-enabling:** Smart grid helps distribution companies in their marketing strategies with less man power.

Table 1: Comparison of General Features of the Existing Power Grid and Smart Grid System

BASIS	EXISTING GRID	SMART GRID
Computer interface	Limited	Broad and Unlimited
Energy Quality	Not essential	Essential with price Factor relation.
Disturbance/Fault Restoration	Analog and un-intelligent	Automatic and self-healing
Power Flow Control	Finite	Inclusive and computerized
Reliability	Non-Automated and Reactive Protection	Automated and Pro-active Protection
Generation of Electricity	Central	Decentralized
Transmission and Distribution lines losses	Loss of Total power $\geq 10\%$ [9,19]	Loss of total power $\geq 2\%$ [9,19]
Negative effects to the Environment	Very high	Relatively low
Grid overall efficiency	Low	High
Monitoring	Blind and Manual	Self-monitoring
Metering System	Electromechanical and Analog	Real – time and Digital
Energy Generation and Storage	Primary Generation sources	Renewable Energy Sources
Operating system integration	Low degree or integration	Full integration
Price information	None or Limited	Full Price information
Switching and Isolation mechanism	Manual	Automated
Faults Response	Failures and Blackouts	Adaptive and Islanding
Communication Method	Non –real time	Real – time
Communication	Non – interactive	Interactive
Participation	Shallow	Intensive
Control	Limited	Penetrating

3.2 Reason of Smart Grid is for the Future

The smart grid has garnered more attention since 2005. Accompanying the realization that ICT presents substantial opportunity to improve the way electrical networks operate has been the realization that the power sector can only be decarbonized at a reasonable cost if it is efficiently managed and regulated [8]. Furthermore, a number of more specific factors have come together recently to spark interest in the smart grid, they include:

- i. **Thermal Constraints:** The maximum power transfer capacity of current transmission and distribution lines and equipment is limited by thermal issues. Power equipment overheats and the insulation deteriorates quickly when it is subjected to current that exceeds its thermal rating. As a result, the equipment's lifespan decreases and the frequency of malfunctions rises. Thus, using dynamic rating occasionally results in an increase in circuit capacity.
- ii. **Security of Supply:** As more and more vital loads are connected, modern civilization needs an electrical supply that is more and more dependable. Other than disconnecting the problematic circuit, there was no need to take any action to sustain supply after a breakdown;

hence the old method of increasing dependability was installing more redundant circuits, at significant capital expense and environmental damage. Using intelligent post-fault reconfiguration is a smart grid strategy that maintains customer supplies following (inevitable) power system faults while avoiding the cost of several circuits that may be partially loaded for a significant portion of their lifespan. Power redundancy circuits maximize asset usage at the expense of increased electrical losses.

The National Institute of Standards and Technology (NIST) was tasked by the Energy Independence and Security Act of 2007 in the United States with coordinating the creation of a framework to enable interoperability of smart grid systems and devices [4]. The following are the expected advantages and needs of smart grid, per the NIST study (177):

- i. Improving power reliability in all sections of power system.
- ii. Improving quality of power at the generation, transmission and distribution.
- iii. Enhancing capacity and efficiency of existing electric power networks.
- iv. Improving resilience to disruption.

- v. Facilitating expanded deployment of renewable energy sources.
- vi. Increasing the choices the consumers may have.
- vii. Accommodating distributed power sources.
- viii. Presenting opportunities to improve grid security.

If the smart grid is put into place, the advantages will apply in our countries. More than 6% of total net generation in the United States was lost in 2008 due to distribution losses of energy, totaling 271 billion kilowatt hours. Xcel Energy projects that by employing system balancing and optimal power factor performance, the smart grid may cut such losses by thirty percent [12].

The swift implementation of smart grid technology across the nation is indicative of the many operational and reliability advantages that utilities anticipate, such as reduced expenses for upkeep and operation as well as the prevention of expensive disruptions.

IV. DISCUSSION

In today's society, securing inexpensive, efficient, and dependable energy is a major concern. These are practically achievable for a sustainable energy future with the use of smart grid technologies. The electrical grid of the twenty-first century may be made more intelligent, adaptable, dependable, self-balancing, and interactive with the use of smart grid technology. This will lead to enhanced consumer control, operational efficiency, environmental supervision, economic growth, and energy security.

From an economic standpoint, a smart grid will save the cost of power outages and large-scale infrastructure construction; in other words, lower utility costs translate into higher system efficiency. Additionally, when private companies develop energy-efficient products, new communication capabilities, and smart meters, the smart grid will open up new markets. The smart grid will benefit electric users by incorporating embedded intelligence into devices like smart meters, smart sensors, and smart control rooms. The advantages of the smart grid will ultimately far exceed the disadvantages.

From generation and transmission standpoint, Companies must balance the need to advance technology with the need to preserve the safe and dependable infrastructure required to provide for their consumers. Utilities need to be willing to weigh the benefits of smart grid enhancements against the necessity of replacing outdated technology. Smart grids are flexible and can receive power from almost any source. The implementation of smart grid technology is expected to enhance industry dependability and lead to cost savings. Modern technology has become increasingly necessary in our environment, and even the smallest fluctuations in power

quality and dependability might result in lost data, productivity, and operations. Such electricity quality and dependability may be significantly improved with the help of a smart grid. Utility companies will be able to detect, locate, and repair power failures faster thanks to smart grids' two-way communication feature, all without needing to dispatch workers on needless excursions. "A smart grid could remove up to 50% of trouble calls." Additionally, a smart grid will contribute to a decrease in the number and length of issue calls, which will increase customer satisfaction and calm utility contact centers. The term "self-healing" refers to the grid's capacity to repair, stop, and prolong the life of its components. Finding dependable and high-quality techniques for producing and transmitting electricity is crucial given the rising need for power and energy. The smart grid can be employed to lower peak demand, which would lessen the need for more transmission lines and power plants to fulfill that need for electricity. Because it can detect indications of malfunctioning equipment and cut down on unnecessary visits, the smart grid may significantly lower operations and maintenance expenses. Smart grid technologies have the ability to drive modifications in power flow and would be more flexible in terms of producing renewable energy. The nation's electrical infrastructure would continue to be more reliable and secure with the implementation of a smart grid.

From consumer's standpoint, Customers will gain from the smart grid in terms of dependability, cost savings, and accessibility to new goods and services. Residential and small business users will have more control over their monthly bills and energy consumption thanks to the modern grid. Customers will have additional options thanks to smart grids to control their energy use and overall costs. They would be able to view their electricity usage instantaneously and take part in energy markets. Big clients will have access to data, such as pricing signals, to help them make energy-efficient decisions. Reduced outage time and increased dependability will be advantageous to local governments. This will lessen the workload on the city's fire, police, and other services when they respond to situations like electrical issues or power outages. Through selective power outages or quicker, more effective power restoration, the grid will enable operators to help during emergencies like storms and fires.

4.1 Possible Challenges of Smart Grid Technology Implementation in Nigeria

All technology has its advantages and drawbacks, while smart grid have their benefits, they also present challenges to electric utilities, customers, and the environment. The drawbacks are:

- Ageing and outdated infrastructure: present infrastructure of the electric network is inadequate and requires major overhaul and augmentation to support the growth of smart grids.
- Lack of integrated communication platform.
- Cost of deployment: Distribution systems make up the bulk of smart grid costs. It is estimated that the cost of upgrading the Nigerian system could cost a lot.
- Management of the vast amount of data generated by a wide range of stakeholders such as the power utilities, vendors, municipalities, IPP, and consumers will be challenging.
- Smart grid cyber security: is another challenge area for smart grid implementation. Use of the internet to link data flow between utilities and customers creates a need to address cyber security. "Remote access to control systems poses a huge danger".
- Make more energy available at affordable prices to enable all people to use modern energy to meet their basic needs.
- To slow overall growth of energy consumption through conservation and energy efficiency improvement and to make energy sources more environmentally sustainable.
- Lack of human skills: who have they "know how" to deal with highly sophisticated equipment.
- Generation of sufficient and enough power in Nigeria. At the moment, the power generated is below 40% of the needed power in Nigeria and it constitute serious challenge to Smart grid implementation.
- Lack of government will to invest or commit large amount of money into power generation, transmission and distribution.

The roadmap to implementation of smart grid should consider the following:

- Strategic Planning: Smart grid needs a coordinated phase by phase implementation and detailed plan spreading over many years covering design, implementation and change management.
- Regulatory Strategy: This is the strategy for recovery of cost and regulatory alignment. Detailed plans on investment and recovery of money invested.
- Complete Approach: Smart grid requires a total approach to operations and business surrounding systems planning, power delivery and customer services. It requires a transformation away from a "Silo -based" business.
- Business Case Justification: It requires a sound business case regarding costs and benefits associated with technologies and business transformation. Leveraging project synergies is a critical factor to the business case justification.

- Enablers and Foundational Capabilities: Identification and implementation of enabling and foundational capabilities, including people and process are critical to the long-term success of these initiatives.
- Interoperability Standards: Establishing enterprise level governance, adopting interoperability standards and developing an architectural framework for data, systems and technology integration is an important step in implementation of smart grid projects.
- Practical, balanced and Leveraged Solutions: The need for business continuity that leverage existing investments demands practical solutions which support current capabilities and interoperate with existing networks and processes [9].

V. CONCLUSION

There are serious concerns regarding Nigeria's electric power network's capacity to continue offering reasonably clean, dependable, and reasonably priced energy services to its people and enterprises. By modernizing the electrical power system and implementing smart-grid technology, the country can better address its projected energy needs. This includes mitigating the effects of climate change by increasing the amount of energy derived from renewable sources and optimizing the efficiency of non-renewable energy processes. Energy storage can significantly help the electric grid meet these challenges by enhancing its operating capabilities, lowering costs and ensuring high reliability, as well as delaying and reducing infrastructure investments. Improvements to the electric grid must maintain a robust and resilient electricity delivery system. It is going to catapult power transmission and distribution into the digital age, securing electricity supply and boosting conservation.

REFERENCES

- [1] Aguero, J. R. (2012): Applications of Smart Grid Technologies on Power Distribution Systems Published in Innovative Smart Grid Technologies (ISGT), 2012 *IEEE PES*.
- [2] Amim, S. M and Wollenberg, F. B. (2005): "Toward a Smart Grid". *September/October Issue of IEEE P & E Magazine* (Vol. 3, No. 5, Pg. 34-41).
- [3] Davidson, M. (2010): "Smart Grid Australia: An Overview," *Technical: Wessex Consult*, Australia, 2010.
- [4] Fang, X., Guoliang, X. and Dejun, Y. (2011): Smart Grid the New and Improved Power Grid: A Survey.
- [5] Fang, X., Misra, S., Xue, G. and Odadzic, B. "ICT and Smart Grid- The New and Improved Power Grid: A Survey," *International Journal of IEEE*

- Communications Surveys & Tutorials*, vol. 14, No. 4, 2011, pp. 944-980.
- [6] Folly. K. A. (2013) "Challenges in Implementing Smart Grid Technologies in Africa" *Pre-conference Workshops*: 13 May, 2013, Cape Town, South Africa.
- [7] Gungor, V. C., Sahin, D., Kocak, T. and Ergut, S. "Smart Grid communications and Networking". *Telekom Technical Report*- 11316-01, April, 2011.
- [8] Janaka, E., Kithsiri, M. L., Jianzhong, W., Akihiko, Y. and Nick, J. (2012) "Smart Grid Technology and Applications". *John Wiley & Sons Ltd, The Atrium, Southern Gate, Chichester, West Sussex, PO198SQ, United Kingdom*.
- [9] Ali Ipekchi "Implementation of the Smart grid: Enterprise Information Integration" *Grid- Interop forum 2007*. Paper 121: 121 – 7.
- [10] Mckinsey (2010). "The smart grid and the promise of demand side management". www.smartgrid.gov.
- [11] Moslehi, K. and Kumar, R. (2010): "Smart Grid-a reliability perspective," *Innovative Smart Grid Technologies (ISGT)*, pp. 1-8, 19-21 Jan. 2010. III-B.
- [12] Oke, V. O. (2015): The Engineering Network Team. Vanguard, July 27, 2015. *Smart Grid*, (2010), <http://www.oe.enrgy.gov/smartgrid.htm>
- [13] Stuart, B. (2012): "Smart Grid: Infrastructure, Technology and Solution". <http://books.google.com>.
- [14] Technical report by US depart of Energy, 2008. "The Smart Grid: An introduction," <http://energy.gov/oe/downloads/smart-grid-introduction>.
- [15] Vehbi, G. (2011): Smart Grid Technologies: Communication Technologies and Standards. *IEEE Transactions on Industrial Informatics*, Vol. 7, No. 4, November 2011.
- [16] Xiaoyu, Ma (2010): Smart Grid, www.csc.wustl.edu.
- [17] Folasade. M.D, Aminat A.O, Adegoke O.M, Akilolu A.P Oluwafemi A.S and Kazeem A.A "Smart Grid Systems in Nigeria: Prospects, Issues, Challenges and Way Forward" *FUOYE Journal of Engineering*, Volume 7 issue 2; June 2022.
- [18] Shaukat, N., Ali, S. M., Mehmood, C. A., Khan, B., Jawad, M., Farid, U., Ullah, Z., Anwar, S. M., & Majid, M. (2018). A survey on consumer empowerment, communication technologies, and renewable generation penetration within Smart Grid. *Renewable and Sustainable Energy Reviews*, 81(May), 1453–1475. <https://doi.org/10.1016/j.rser.2017.05.208>
- [19] Amuta, E., Wara, S., Agbetuyi, A., & Matthew, S. (2018). Smart Grid Technology Potentials in Nigeria: An Overview. *International Journal of Applied Engineering Research*, 13(02), 1191–1200.

Citation of this Article:

Eleje E.N., Ejimofor I.A., & Ani S.E. (2024). The Effect of Smart Grid Technology for Future Energy Sustainability in Nigeria's Power System. *International Research Journal of Innovations in Engineering and Technology - IRJIET*, 8(10), 206-212. Article DOI <https://doi.org/10.47001/IRJIET/2024.810027>
