

# A Review on Thermodynamic Modeling and Optimization Strategies for Thermal Management in Electric Vehicle Batteries

Ajay Haribhau Jadhav

Professor, Department of Mechanical Engineering, Mahavir Polytechnic Nashik, Maharashtra, India

**Abstract** - Conventional fuels operated an internal combustion engines are the major sources of carbon emissions and it causes environmental degradation. Electric vehicles (EVs) offers best efficient and cost effective solution for the above said issue. By year 2030 the world is aiming to shift to electric vehicles and one of the hurdles in the path is thermal management in the battery. This study aims to evaluate the performance of popular cooling methods thermodynamically. Lithium -ion batteries are the most commonly used battery type in commercial electric vehicles due to their high energy densities and ability to be repeatedly charged and discharged over many cycles. In order to maximize the efficiency of a li-ion battery pack, a stable temperature range between 15°C to 35°C must be maintained. Battery thermal management system (BTMS) plays a crucial role in enhancing the performance, safety and lifespan of electric vehicle batteries by maintaining optimal temperature conditions. This paper reviews how heat is generated across a li-ion cell as well as the current research work being done on the four main battery thermal management types which include air-cooled, liquid-cooled, phase change material based and thermo-electric based systems. Additionally, the strengths and weaknesses of each battery thermal management type is reviewed in this study. It was determined that air cooled systems are suited for short-distance travel electric vehicles, liquid cooled are for electric vehicles that require long-distance travel, larger battery packs and for high thermal loads, phase change material based are for electric vehicles with constant thermal loads and stable ambient temperatures and thermo-electric battery thermal management systems are best suited in conjunction with the other types for better control.

**Keywords:** Battery thermal management, Electric vehicle, air cooling, liquid cooling, PCM cooling, thermo-electric.

## I. INTRODUCTION

With the increasing demand to lower the carbon footprint of the transport sector, automobile manufacturers are rapidly

developing electric vehicle (EV) technologies and increasing EV production. In 2021 alone, the global sales of EVs reached 6.6 million which tripled the 2019 sales figures [1]. Despite the growth in demand, there are still several factors that hinder the widespread adoption of EVs in the general automotive market. Among the issues faced by consumers are the EV's lack of reliability for long-distance travel and the EV's short vehicular lifespan, particularly with regard to the longevity of the EV's battery pack [2].

Vehicle charging infrastructure is still not properly developed in most part of the world [3]. The transmission systems as well as the motors are quite well established and efficient. The thermal management is a major limitation that could hinder the development of EVs, especially that pertaining to the battery [3] and motor [4]. Poor battery thermal management could lead to thermal runaway or poor battery life while poor motor thermal management could damage the magnets and hamper the magnetic field development [4].

There are several factors that affect the performance of an EV battery pack but the main factor is its susceptibility to thermal effects. A conventional EV li-ion battery pack operates optimally between 15 °C to 35 °C. If the li-ion battery pack operates below 15 °C, the overall capacity drops and the battery's internal resistance increase [5]. Conversely, temperatures above 35 °C could potentially lead to an irreversible reaction occurring across the li-ion battery pack and an increased risk of thermal runaway [6]. Additionally, it can also accelerate the capacity drop of the li-ion battery [7].

The main aim of the BTMS is to regulate the temperature of the cells of the battery and thereby increase the lifespan of the battery. There are two main types of BTMS: active systems and passive systems. The active system mainly depends on forced circulation of a specific coolant such as water or air. A passive system uses method like heat pipes, hydrogels and phase change materials to have zero power consumption and thus improves the net efficiency of the vehicle.

Various thermal management strategies are employed in EVs which include air cooling, liquid cooling, solid-liquid phase change material (PCM) based cooling and thermo-electric element based thermal management [8]. Each battery thermal management system (BTMS) type has its own advantages and disadvantages in terms of both performance and cost. For instance, air cooling systems have good economic feasibility but may encounter challenges in efficiently dissipating heat during periods of elevated thermal stress. In contrast, liquid cooling, whether implemented through direct or indirect methodologies, exhibits notable effectiveness in heat dissipation, albeit potentially incurring greater implementation costs. PCM based cooling mechanisms utilize the large latent heat capacities of materials undergoing phase transitions between solid and liquid states to conduct heat away from the battery packs which demonstrates potential in enhancing thermal regulation. However PCMs have low thermal conductivity which will have to be enhanced through the integration of thermally conductive materials [9]. In this paper, a detailed comprehensive of BTMS are reviewed from the available works of the literature.

systems. The sub-categories for each system are displayed in Fig. 1. The most commonly used BTMS types in EVs are air and liquid based cooling because the cooling capacity can be actively optimized depending on the thermal load of the battery as compared to other passive cooling methods such as PCM and heat pipe BTMS types [10].

Air based BTMS uses air flow to convect heat away from the li-ion battery pack. It is divided into Natural Ventilation and Forced Convection systems. Liquid Based BTMS is separated into Direct and Indirect systems. Direct cooling involves the submersion of the li-ion battery pack in a dielectric coolant such as oils and engineered fluids to conduct heat away from the battery. Meanwhile, indirect cooling involves channeling a coolant through a medium such as a cooling plate with integrated tubing channels or looping a cooling ribbon across the battery pack to conduct heat away. The application of passively cooled BTMS type in electric vehicles is limited due to the insufficient cooling capacity and can only be used within a certain thermal load range. Consequently, EVs employing passive cooling are restricted to a singular charging profile and have limited acceleration to limit its power draw from the li-ion battery to avert excessive heat generation.

Examples of passive cooling BTMS include PCM and thermoelectric-based systems. PCM based BTMS utilize materials that have high latent heat capacities to allow them to conduct large quantities of heat passively during their solid to liquid transition. There are two main types of PCMs, organic and inorganic. Organic PCMs are chemically stable, non-corrosive and have high latent heat capacities and have melting temperatures between 15 °C-130 °C. Their main weaknesses are their combustibility and poor thermal conductivity [12,13]. Inorganic PCMs are non-combustible, have high latent heat energy, are good thermal conductors and have low thermal expansions. However, the melting temperature of inorganic PCMs are between the 307 °C to 380 °C and 700 °C to 900 °C range making them unsuitable as a BTMS for li-ion battery packs [14]. The thermoelectric element consists of a thermoelectric generator (TEG) and thermoelectric cooler (TEC). The TEG cools the li-ion battery pack by converting heat from the battery pack to electricity through the seeback effect while the TEC converts electricity to heat through the Peltier effect to warm the battery pack when needed [15].

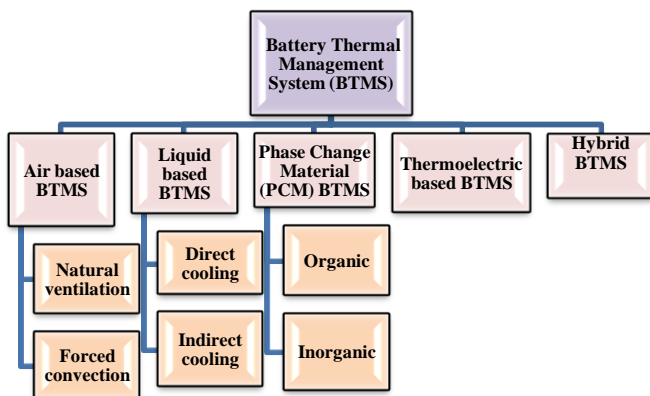

Figure 1: Different BTMS types utilized for EV li-ion battery packs

## II. EV BATTERY THERMAL MANAGEMENT SYSTEMS (BTMS)

The BTMS of an EV plays an important role in extending the lifespan of li-ion battery pack by optimizing the batteries operational temperature and minimizing the risk of thermal runaway. There are several traits that a good BTMS should have which include maintaining the li-ion battery pack temperature between 15 °C - 35 °C, be light, compact and energy efficient, reasonably priced, even regulation of battery cell temperature throughout the pack and provide sufficient ventilation in the event that toxic fumes are leaked from a li-ion battery fire [8, 11].

There are various BTMS types utilized in the automotive industry which include Air based, liquid based, PCM thermal management based, thermoelectric element based and hybrid

### 2.1 Air based BTMS

Air based BTMS have distinct advantages over liquid, PCM and thermoelectric based BTMS including the utilization of a direct, low risk, non-viscous coolant, is compact and lightweight in design, lower cost ,requires low maintenance

and has better reliability [16]. Active cooling BTMSs such as with thermoelectric thermal management and liquid based BTMS require additional energy to operate either the pump, TEG or TEC system resulting in reduced mileage of the EV [17]. However, this difference in efficiency is only applicable at low heat load conditions. Under extreme heat load conditions such as charge-discharge rate or high ambient temperature, air-based BTMS consumes more energy than liquid and thermoelectric BTMS. [18,19] Similarly, PCM BTMSs are also more efficient than air based BTMS at high thermal loads [20]. However, most PCM BTMSs will be significantly heavier as large quantities of PCMs are required to ensure that the PCM Latent Heat capacity matches the heat produced by the li-ion battery pack [20]. Air based BTMS are suitable for low heat load li-ion battery applications and is significantly lighter than other BTMS types. Among the EVs and hybrid EVs that use air based BTMS includes the Honda Fit EV, Honda Insight, Hyundai IONIQ, Toyota Prius Prime, [20,21].

### 2.1.1 Natural ventilation and forced convection

Air based BTMSs typically operate under two modes, natural ventilation and forced convection. When there is a low thermal load and the EV is moving, natural ventilation is achieved when the ambient airflows into the inlet of the li-ion battery pack through the motion of the vehicle and exits at the outlet [20].

The ambient air circulates through the gaps between the li-ion battery cells dissipating heat away from the battery pack. Another form of passive cooling involves redirecting air from the cabin to the battery pack. The cooled cabin air can be directed to the battery pack to improve cooling performance through additional ducting. Those forms of cooling will not be sufficient if the vehicle is not moving at sufficient velocity, if the ambient temperature is too high or if the general thermal load of the battery is too high. The thermal gradient of the li-ion battery pack will be uneven which could lead to lower uniformity in charge or discharge rates across the battery pack [22]. By controlling the fan or blower speeds at either the inlet or the outlet, the temperature of the battery pack can be regulated based on the thermal load of the battery pack. Additional ducting is installed from the fan or blower to go before the heater and evaporator coils of the EV to ensure greater air flow rates pass through the battery pack.

## 2.2 Liquid based BTMS

The main advantage of a liquid based BTMS is that it is able to achieve higher heat transfer rates with lower flow rates in comparison with air cooled systems [23]. Various types of fluids are used as coolants for liquid based BTMS including water, oils, water containing suspended metallic particles and

ethylene glycol [24]. As each fluid type has different viscosity and specific heat capacity values, the selected fluid type is dependent on the amount of heat that is needed to be absorbed as well as the mechanical energy required to channel the fluid around the battery pack. Liquid based BTMS is divided into two categories which are indirect and direct cooling with the main difference being that indirect cooling requires the coolant to be physically separated from the li-ion battery while the latter requires the coolant in full contact with the li-ion battery pack.

### 2.2.1 Direct liquid cooling

Direct liquid cooling is to cool the li-ion battery pack by immersing it in a non-electrically conductive dielectric fluid with high specific heat capacities to cool the battery. Various dielectric fluids are used for immersion cooling but the most common types are deionized water, silicon oils, mineral oils and fluorinated hydrocarbon [25,26]. There is continuous research on developing better immersion fluids aside from the common types. When compared with other coolant types, the supercritical CO<sub>2</sub> had better temperature suppression and uniformity even at high discharge rates.

Immersion cooling fluids utilized for BTMS applications have high flash points and are non-volatile in nature that reduces the risk of thermal runaway in the battery pack [27]. Immersion cooling is divided into two modes which are single-phase cooling and two-phase cooling. With single-phase cooling, the coolant remains in a liquid form and gets pumped through a heat exchanger. Two-phase cooling involves utilizing a coolant with low boiling temperatures to vaporize the coolant and its vapor cooled back to liquid form through a water condenser unit. The latent heat of vaporization during the liquid to vapor transition of a two-phase system improves the convective heat transfer significantly but in terms of EV BTMS applications there are some disadvantage as compared to the single-phase system [25]. These disadvantages includes gradual loss of coolant fluid due to inefficiencies of the condenser unit, increased system complexity, higher maintenance cost, increased system volume and risk of coolant vapor contamination to the other electronic components at the undercarriage of the EV. As such, for EV applications a single-phase immersion cooled battery pack is preferred over two-phase immersion packs due to its ease of maintenance and relatively lower costs.

### 2.2.2 Indirect liquid cooling

Indirect liquid cooling involves channeling a coolant through a cooling medium that allows a fluid to absorb the heat away from the battery pack while preventing a short circuit from occurring between the liquid medium and the li-ion battery pack itself. Some commonly used indirect cooling

methods include cooling plates, thermally conductive tubing or through a heat pipe to conduct heat away from the li-ion battery pack.

In indirect liquid cooling, the liquid is not in contact with the cells but the liquid passes through a conduct, in general cold plates [28–29] or tubes [30]. The main advantage of indirect contact cooling is that also non-dielectric fluids can be used. In general, the utilized liquids, water or ethylene glycol, have a lower viscosity than oil resulting in less energy requirements from the pump [31]. If coupled with a chiller for liquid refrigeration, this system can maintain the correct battery temperature even in the worst environmental conditions with a compact design. However, due to the added complexity, there is a weight increment, maintenance issues and the risk of liquid leakage [32]. Indirect liquid cooling, although presenting a higher thermal resistance with respect to direct liquid cooling, shows the best performance. Indirect liquid cooling could be a better solution for practical applications [33].

### 2.3 Phase change material BTMS

The high latent heat capacity that phase change materials (PCM) have allows PCM based BTMS systems to absorb large quantities of heat while being maintained at a constant temperature range without active energy consuming components such as fans or pumps. This in turn allows PCM based BTMS systems to be more efficient than air and liquid based BTMS due to the lack of parasitical power being drained from the battery pack. There are generally two types of PCMs which are organic and inorganic based PCMs each with their own distinct chemical and thermal properties.

#### 2.3.1 Organic PCMs

Organic PCMs are further divided into two categories which are paraffins and non-paraffins such as with fatty acids, glycols and sugar alcohols [34]. Organic PCMs have several advantages which allow them to be better suited for EV BTMS applications which include being noncorrosive, non-toxic and chemically stable. However, organic PCMs have low thermal conductivity, are combustible which would be hazardous in the event of thermal runaway and is less viscous as compared to inorganic PCMs which would increase the risk of the PCM leaking through the container during the solid to liquid phase transition [35]. There are various methods to improve the thermal conductivity of organic PCMs but there are generally three methods which include the addition of fins, encapsulating the PCM in a thermally conductive coating and the addition of thermally conductive fillers such as with graphite nano-particles and metallic foams [36].

#### 2.3.2 Inorganic PCMs

There are various types of inorganic PCMs which include molten salts, hydrated salts and metals with several advantageous properties for thermal energy storage applications such as having a higher latent heat capacity, non-flammability and they have relatively low cost as compared to organic PCMs. However, the main reason most researchers do not utilize inorganic PCMs is because of its corrosive properties, higher phase change temperatures, similarly poor thermal conductivity, heaviness, lack of stability for repeated phase change cycles due to phase separation, dehydration and sub-cooling [6,37,38]. The main impediment to its adoption for thermal energy storage applications is its dehydration factor which would cause the inorganic PCM to be unstable [39]. Ling et al. [39] attempted to overcome such a disadvantage through a multi-scale encapsulation method of an inorganic PCM, sodium acetate trihydrate urea with the goal of preventing dehydration and improving its thermal conductivity. At present, there are not many alternative techniques to deal with the chemical instability of the inorganic PCM which is the main reason why it is not widely adopted for BTMS applications. Hence, increased development in this area is needed for wider adoption.

#### 2.4 Thermoelectric based BTMS

Thermoelectric power generation and thermoelectric coolers (TECs) are also advantageous as BTMS's for they are relatively silent, stable and have better temperature control features through fine adjusting of the voltage [19]. Generally, thermoelectric devices involves converting temperature differences between a cold segment and the heating segment to electric current and vice versa through the Peltier–Seebeck effect along with the Thomson effect. There is a major drawback for thermoelectric systems for BTMS applications in which such systems have low thermal efficiencies and would require additional energy to operate which would lower the thermal efficiency of the battery pack itself [40]. Most literature works would construct hybrid systems between TECs and other forms of cooling including air, liquid and PCM cooling. Lyu et al. [19] constructed a liquid, air, TEC hybrid system to cool a simulated heat load. A cylindrical heat load which was meant to represent a li-ion cell encased in a copper cylinder and suspended in a water storage and is pumped through a TEC cooling system that is further cooled by a cooling fan. A constant 40 V was supplied to the heater module, 12 V was supplied to the TEC device and the heater module is heated for one hour to mimic a li-ion cell undergoing a 1C discharge rate. At the end of the heat load test, the surface temperature of the simulated li-ion cell dropped from 55 °C to 12 °C which was a considerably large temperature drop.

Table 1: Strengths and weaknesses of passive BTMS system

BTMS	Mode of cooling	Strengths	Weaknesses
<b>Air cooling</b>	Natural ventilation	<ol style="list-style-type: none"> <li>1.Low energy requirements</li> <li>2.Light weight</li> <li>3.Simplistic design</li> <li>4.Ease of maintenance</li> <li>5.Low operational cost</li> <li>6.Direct cooling medium contact</li> </ol>	<ol style="list-style-type: none"> <li>1.Insufficient cooling capacity</li> <li>2.Low cooling efficiency</li> <li>3.Unbalanced thermal distribution</li> </ol>
<b>Liquid cooling</b>	Heat pipe	<ol style="list-style-type: none"> <li>1.High specific heat capacity</li> <li>2. High thermal efficiency</li> <li>3.Large cooling surface area</li> </ol>	<ol style="list-style-type: none"> <li>1.Occupies large volume</li> <li>2.Complex structure</li> <li>3.Costly</li> <li>4.Leakage problem</li> <li>5.Condenser section has to be cooled</li> </ol>
<b>PCM</b>	Organic PCM	<ol style="list-style-type: none"> <li>1.Low cost</li> <li>2.Chemically stable and reliable (Has to be enhanced)</li> <li>3.Uniformed temperature distribution</li> <li>4.High latent heat capacity</li> <li>5.Able to operate passively</li> </ol>	<ol style="list-style-type: none"> <li>1.Low thermal conductivity</li> <li>2.Leakage problem</li> <li>3.Narrow melting temperature range</li> <li>4.Combustible</li> </ol>
	Inorganic PCM	<ol style="list-style-type: none"> <li>1.Low cost</li> <li>2.Uniformed temperature distribution (Has to be enhanced)</li> <li>3.High latent heat capacity</li> <li>4.Able to operate passively</li> <li>5. Non-combustible</li> </ol>	<ol style="list-style-type: none"> <li>1.Low thermal conductivity</li> <li>2.Leakage problem</li> <li>3.Narrow melting temperature range</li> <li>4.High melting temperature</li> <li>5.Chemically unstable</li> <li>6.Corrosive</li> <li>7.Heavy</li> </ol>

Table 2: Strengths and weaknesses of active energy BTMS systems

BTMS	Mode of cooling	Strengths	Weaknesses
<b>Air Cooling</b>	Forced convection (Fan Cooling)	<ol style="list-style-type: none"> <li>1.Direct cooling medium</li> <li>2. Light-weight</li> <li>3.Simplistic design</li> <li>4.Ease of maintenance</li> </ol>	<ol style="list-style-type: none"> <li>1. Low specific heat</li> <li>2. Requires additional fan</li> <li>3.Unbalanced thermal distribution</li> <li>4.Low cooling efficiency</li> </ol>
<b>Liquid Cooling (Indirect)</b>	Cooling plate	<ol style="list-style-type: none"> <li>1.High specific heat capacity</li> <li>2. High thermal efficiency</li> <li>3. Large cooling surface area</li> </ol>	<ol style="list-style-type: none"> <li>1.Costly</li> <li>2. Risk of leakage</li> <li>3.Complicated machining required</li> <li>4. Not suitable for cylindrical cells</li> <li>5. Requires additional pump</li> <li>6. Short operational lifetime</li> </ol>
	Thermally conductive Tubing	<ol style="list-style-type: none"> <li>1. High specific heat capacity</li> <li>2. High thermal efficiency</li> <li>3. Large cooling surface area</li> <li>4. Flexible</li> </ol>	<ol style="list-style-type: none"> <li>1. Risk of tubing leakage</li> <li>2. Short operational lifetime</li> <li>3. Costly</li> <li>4. Requires additional pump</li> </ol>

<b>Liquid cooling (Direct)</b>	Immersion cooling	<ol style="list-style-type: none"> <li>1.High specific heat capacity</li> <li>2.High thermal efficiency</li> <li>3. Occupies least volume</li> <li>4.Large cooling area</li> </ol>	<ol style="list-style-type: none"> <li>1.Risk of leakage</li> <li>2.Costly</li> <li>3.Heavy</li> <li>4.Complex structure</li> <li>4. Requires additional pump</li> </ol>
<b>Thermoelectric</b>	Thermoelectric cooler	<ol style="list-style-type: none"> <li>1.Low maintenance cost</li> <li>2.Non combustible</li> <li>3.Structurally stable</li> <li>4. No risk of leakage</li> <li>5. Static component</li> <li>6. Accurate temperature control</li> </ol>	<ol style="list-style-type: none"> <li>1.Low thermal efficiency</li> <li>2.Additional power requirement</li> </ol>

### III. RESULTS AND DISCUSSIONS

From the review study conducted, it can be deduced that each BTMS system has its own set of strengths and weaknesses that allow them to be favorable for different battery pack specifications. Distinctively, each BTMS can be categorized into passive and active energy systems as presented in Tables 1 and 2 respectively. Air cooling through natural ventilation is the cheapest and most simplistic mode of cooling for a battery pack but it does not provide sufficient cooling for most EV applications due to its low heat capacity and heat transfer coefficients [15].

PCM’s show favorable traits as a passive BTMS system as they are able to absorb large quantities of heat and maintain optimal temperatures for prolonged periods due to the high latent heat capacity of the PCM during its phase change transition. PCM BTMSs are also more compact in space requirements as an active cooling component is not needed. However, PCMs require a significant amount of time to resolidify after it melts, there is the risk of the PCM leaking during its liquid state and the large latent heat capacity is only accessible at narrow temperature ranges which prevents the PCM from responding to rapid temperature rises and drops across the battery pack. For organic PCMs, there is also the risk of combustibility in the event of a thermal runaway scenario while inorganic PCMs are chemically unstable after several phase change cycles, have higher melting temperatures and are heavier than organic PCMs. To improve the quality of PCM based BTMS, the container of the PCM has to enhance the thermal conductivity of the PCM, prevent it from leaking and ensure the homogeneity of the PCM over several charge cycles. Hence a PCM BTMS based on thermally conductive coating or a finned container would be the ideal container type. EVs designed for long distance travel and fast charging require larger battery packs which would produce much higher thermal loads.

As such, it is necessary to implement an active cooling based system to dissipate the large quantities of heat generated and accurately control the cooling energy needed to maximize

the efficiency of the cooling system. Immersion cooling offers the greatest cooling efficiency and best cooling uniformity as compared to the other liquid cooling strategies. By soaking the battery pack in dielectric fluid, the cooling surface area available is maximized and coupled with the high specific heat capacity of the dielectric fluid the battery pack is able to achieve high charge and discharge rates. The risk of thermal runaway is also greatly reduced due to the non-flammability of the dielectric fluid [71]. Most dielectric fluids are costly though and a substantial volume of it is required to cool the entire battery pack. Hence, immersion cooling is better suited towards high performance EVs that produce high thermal loads. By examining the strengths and weaknesses across each type of BTMS type, it becomes apparent that certain BTMS variants are better suited for specific types of EV types.

### IV. CONCLUSION

This study reviews the latest developments in BTMS technologies as well as explores the strengths and weaknesses of each BTMS type available. Essentially there are four types of BTMS systems available in the EV industry which include air cooled, liquid cooled, PCMs and thermo-electric based BTMS. There are also hybrid systems which combine the components of two or more BTMS types such as with a combination of air and liquid cooled systems to improve upon the cooling performance of a singular BTMS type. Air cooled systems have low energy requirements, require the least amount of maintenance and are cheap to install but they do not provide sufficient cooling efficiencies for battery packs with high thermal loads.

Hence it is better suited for EVs that are designed for short distance travel and have low thermal load requirements. Liquid cooled BTMS have better heat transfer coefficients, higher specific heat capacities and more uniformed cooling distributions than air but are costlier, heavier, and require much more maintenance. EV’s that have larger battery packs, are catered for long-distanced travel and produce high thermal loads are best suited for this type of BTMS. PCM BTMS types are able to absorb large quantities of heat during its phase change cycle and are able to operate passively. However, the

thermal conductivity of the system is low and the high latent heat capacity is only available at a narrow temperature range. Thermo-electric cooling offers greater temperature control but has insufficient cooling efficiencies as a standalone system to be used as a BTMS. Hence it should be coupled with other BTMS types to accurately control the temperature of such battery packs. Hybrid BTMS are able to combine the strengths of two or more BTMS types but would further increase the complexity and cost of the BTMS. Thus, the hybrid BTMS combination chosen should balance out the advantages and disadvantages of each system before being implemented.

## REFERENCES

- [1] Leonardo P, Gül T. Electric cars fend off supply challenges to more than double global sales. *Int Energy Agency* 2022;1.
- [2] Krishna G. Understanding and identifying barriers to electric vehicle adoption through thematic analysis. *Transp Res Interdiscip Perspect* 2021;10:100364.
- [3] Das, H.S., Rahman, M.M., Li, S., Tan, C.W. 2020. Electric vehicles standards, charging infrastructure, and impact on grid integration: A technological review. *Renewable and Sustainable Energy Reviews*, 120, 109618.
- [4] Tikadar, A., Johnston, D., Kumar, N., Joshi, Y., Kumar, S. 2021. Comparison of electro-thermal performance of advanced cooling techniques for electric vehicle motors. *Applied Thermal Engineering*, 183, 116182.
- [5] University B. BU-502: Discharging at high and low temperatures. *Batter Portable World* 2021;1.
- [6] Lucia Ianniciello PA. Electric vehicles batteries thermal management systems employing phase change materials. *J Power Sources* 2018;378:383–403.
- [7] Panchal S, Pierre V, Cancian M, Gross O, Estefanous F, Badawy T. Development and validation of cycle and calendar aging model for 144ah NMC/Graphite Battery at multi temperatures, dods, and C-rates. 2023.
- [8] Shahjalal M, Shams T, Islam ME, Alam W, Modak M, Hossain SB, Ramadesigan V, Ahmed MR, Ahmed H, Iqbal A. A review of thermal management for Li-ion batteries: Prospects, challenges, and issues. *J Energy Storage* 2021;39:102518.
- [9] Weng J, Ouyang D, Yang X, Chen M, Zhang G, Wang J. Optimization of the internal fin in a phase-change-material module for battery thermal management. *ApplThermEng* 2020;167:114698.
- [10] Akbarzadeh M, Kalogiannis T, Jaguemont J, Jin L, Behi H, Karimi D, Beheshti H, Van Mierlo J, Berecibar M. A comparative study between air cooling and liquid lithium-ion battery module. *ApplThermEng* 2021;198:117503.
- [11] Peng Y, Yang L, Ju X, Liao B, Ye K, Li L, Cao B, Ni Y. A comprehensive investigation on the thermal and toxic hazards of large format lithium-ion batteries with LiFePO4 cathode. *J Hard Mater* 2020;381:120916.
- [12] Joybari MM, Haghghat F, Seddegh S, Al-Abidi AA. Heat transfer enhancement of phase change materials by fins under simultaneous charging and discharging. *Energy Convers Manage* 2017;152:136–56.
- [13] Gilart P, Martinez A, Barriuso M, Martinez C. Development of PCM/carbonbased composite materials. *Sol Energy Mater Sol Cells* 2012;107:205–11.
- [14] Biswas K, Lu J, Soroushian P, Shrestha S. Combined experimental and numerical evaluation of a prototype nano-PCM enhanced wallboard. *Appl Energy* 2014;131:517–29.
- [15] Kim J, Oh J, Lee H. Review on battery thermal management system for electric vehicles. *ApplThermEng* 2019;149:192–212.
- [16] Westbrook MH. The electric car: development and future of battery, hybrid and fuel-cell cars. *Energy engineering, Institution of Engineering and Technology*; 2001.
- [17] Arasu M, Ahmed Q, Rizzoni G. Optimizing battery cooling system for a range extended electric truck. 2019.
- [18] Chang Y-W, Chang C-C, Ke M-T, Chen S-L. Thermoelectric air-cooling module for electronic devices. *ApplThermEng* 2009;29(13):2731–7.
- [19] Lyu Y, Siddique A, Majid S, Biglarbegian M, Gadsden S, Mahmud S. Electric vehicle battery thermal management system with thermoelectric cooling. *Energy Rep* 2019;5:822–7.
- [20] Ling Z, Zhang Z, Shi G, Fang X, Wang L, Gao X, Fang Y, Xu T, Wang S, Liu X. Review on thermal management systems using phase change materials for electronic components, Li-ion batteries and photovoltaic modules. *Renew Sustain Energy Rev* 2014;31:427–38.
- [21] Engineer CF. Battery cooling techniques in electric vehicle. 2022, p. 1.
- [22] Pesaran A, Kim GH. Battery thermal management system design modeling. 2006.
- [23] Han T, Yen C-H, Khalighi B, Kaushik S. Li-ion battery pack thermal management: Liquid vs air cooling. *J ThermSciEngAppl* 2018;11.
- [24] Deng Y, Feng C, E J, Zhu H, Chen J, Wen M, Yin H. Effects of different coolants and cooling strategies on the cooling performance of the power lithium ion

- battery system: A review. *Appl Therm Eng* 2018;142:10–29.
- [25] Roe C, Feng X, White G, Li R, Wang H, Rui X, Li C, Zhang F, Null V, Parkes M, Patel Y, Wang Y, Wang H, Ouyang M, Offer G, Wu B. Immersion cooling for lithium-ion batteries – A review. *J Power Sources* 2022;525:231094.
- [26] Pambudi NA, Sarifudin A, Firdaus RA, Ulfa DK, Gandidi IM, Romadhon R. The immersion cooling technology: Current and future development in energy saving. *Alex Eng J* 2022;61(12):9509–27.
- [27] Suresh Patil M, Seo J-H, Lee M-Y. A novel dielectric fluid immersion cooling technology for Li-ion battery thermal management. *Energy Convers Manage* 2021;229:113715.
- [28] Huo, Y.; Rao, Z.; Liu, X.; Zhao, J. Investigation of power battery thermal management by using mini-channel cold plate. *Energy Convers.Manag.*2015, 89, 387–395.
- [29] Deng, T.; Zhang, G.; Ran, Y. Study on thermal management of rectangular Li-ion battery with serpentine-channel cold plate. *Int. J. Heat Mass Transf.* 2018, 125, 143–152.
- [30] Zhou, H.; Zhou, F.; Zhang, Q.; Wang, Q.; Song, Z. Thermal management of cylindrical lithium-ion battery based on a liquid cooling method with half-helical duct. *Appl. Therm. Eng.* 2019, 162, 114257.
- [31] Jin, L.W.; Lee, P.S.; Kong, X.X.; Fan, Y.; Chou, S.K. Ultra-thin minichannel LCP for EV battery thermal management. *Appl. Energy* 2014, 113, 1786–1794.
- [32] Krüger, I.L.; Limperich, D.; Schmitz, G. Energy Consumption Of Battery Cooling In Hybrid Electric Vehicles. In *Proceedings of the International Refrigeration and Air Conditioning Conference*, Purdue, IN, USA, 16–19 July 2012; pp. 1–10.
- [33] Thakur, A.K.; Prabakaran, R.; Elkadeem, M.R.; Sharshir, S.W.; Arıcı, M.; Wang, C.; Zhao, W.; Hwang, J.Y.; Saidur, R. A state of art review and future viewpoint on advance cooling techniques for Lithium-ion battery system of electric vehicles. *J. Energy Storage* 2020, 32, 101771.
- [34] Faraj K, Khaled M, Faraj J, Hachem F, Castelain C. A review on phase change materials for thermal energy storage in buildings: Heating and hybrid applications. *J Energy Storage* 2021;33:101913.
- [35] Liu C, Xu D, Weng J, Zhou S, Li W, Wan Y, Jiang S, Zhou D, Wang J, Huang Q. Phase change materials application in battery thermal management system: A review. *Materials* 2020;13:4622.
- [36] Abdulateef AM, Mat S, Abdulateef J, Sopian K, Al-Abidi AA. Geometric and design parameters of fins employed for enhancing thermal energy storage systems: a review. *Renew Sustain Energy Rev* 2018;82:1620–35.
- [37] Liu H, Wei Z, He W, Zhao J. Thermal issues about Li-ion batteries and recent progress in battery thermal management systems: A review. *Energy Convers Manage* 2017;150:304–30.
- [38] Jaguemont J, Omar N, Van den Bossche P, Mierlo J. Phase-change materials (PCM) for automotive applications: A review. *Appl Therm Eng* 2018;132:308–20.
- [39] Ling Z, Li S, Cai C, Lin S, Fang X, Zhang Z. Battery thermal management based on multiscale encapsulated inorganic phase change material of high stability. *Appl Therm Eng* 2021;193:117002.
- [40] Siddique ARM, Mahmud S, Heyst BV. A comprehensive review on a passive (phase change materials) and an active (thermoelectric cooler) battery thermal management system and their limitations. *J Power Sources* 2018;401:224–37.

#### AUTHOR'S BIOGRAPHY



**Ajay Haribhau Jadhav**, Professor at Department of Mechanical Engineering, Mahavir Polytechnic, Nashik, India.

#### Citation of this Article:

Ajay Haribhau Jadhav. (2024). A Review on Thermodynamic Modeling and Optimization Strategies for Thermal Management in Electric Vehicle Batteries. *International Research Journal of Innovations in Engineering and Technology - IRJIET*, 8(12), 175-182. Article DOI <https://doi.org/10.47001/IRJIET/2024.812026>

\*\*\*\*\*