

RationX - Smart, Next-Generation Ration Distribution System

¹Shantanu Kale, ²Rohit Rathod, ³Pujan Mendhule, ⁴Chaitali Rajee

^{1,2,3}Student, Electronics and Tele-Communication Engineering, Dr. D Y Patil Institute of Technology, Pimpri, Pune, Maharashtra, India

⁴Asst. Professor, Electronics and Tele-Communication Engineering, Dr. D Y Patil Institute of Technology, Pimpri, Pune, Maharashtra, India

Abstract - The Public Distribution System (PDS) plays a crucial role in providing essential food commodities to economically weaker sections of society. However, traditional ration distribution methods suffer from issues such as manual errors, identity fraud, corruption, and lack of transparency. To overcome these challenges, this paper presents RationX – Smart, Next-Generation Ration Distribution System, an IoT-enabled automated ration distribution model integrated with biometric authentication and real-time communication. The proposed system is built around the Arduino Mega 2560 microcontroller and incorporates an R307 fingerprint sensor for secure beneficiary authentication. Once authenticated, the user can select the required ration quantity through a keypad interface. The system verifies the allocated quota and activates a motor-driven dispensing mechanism using an L298N motor driver to deliver the precise quantity. After successful distribution, a GSM module sends an SMS notification to the beneficiary, while an IoT module uploads transaction details to a cloud server for centralized monitoring and digital record maintenance. The integration of biometric security, automated dispensing, SMS alerts, and cloud-based monitoring ensures transparency, reduces fraudulent practices, and minimizes human intervention. The proposed system enhances operational efficiency and reliability in fair price shops and can be scaled for nationwide deployment. RationX provides a cost-effective and secure solution to modernize the existing ration distribution infrastructure.

Keywords: Smart Ration Distribution System, Public Distribution System (PDS), Biometric Authentication, IoT, Arduino Mega 2560, GSM Module, Fingerprint Sensor (R307), Automated Dispensing, Cloud Monitoring, Embedded Systems.

I. INTRODUCTION

The Public Distribution System (PDS) is one of the most significant welfare initiatives implemented by the Government

of India to ensure food security for economically weaker sections of society. Through fair price shops, essential commodities such as rice, wheat, sugar, and kerosene are distributed to eligible beneficiaries at subsidized rates. Despite its noble objective, the traditional ration distribution mechanism faces numerous challenges, including manual record maintenance, identity fraud, inaccurate quantity measurement, corruption, stock mismanagement, and lack of transparency. These issues reduce system efficiency and prevent benefits from reaching the rightful recipients.

In the conventional system, beneficiary verification is primarily done using ration cards and manual registers. This approach is highly vulnerable to duplication, fake entries, and unauthorized access. Additionally, manual weighing and distribution of food grains often result in inaccurate measurements and disputes between shopkeepers and consumers. The absence of a real-time monitoring mechanism further limits the ability of authorities to track transactions and ensure accountability. Therefore, there is a strong need for a secure, automated, and transparent ration distribution model that minimizes human intervention and eliminates malpractices.

To address these problems, **RationX – Smart, Next-Generation Ration Distribution System** is proposed as an IoT-based automated solution integrating biometric authentication, embedded control, and real-time communication. The system is designed to modernize fair price shops by introducing secure identity verification using a fingerprint sensor, automated ration dispensing using a motor-controlled mechanism, and digital transaction logging through IoT connectivity. By combining hardware automation with cloud-based monitoring, the system enhances reliability, transparency, and operational efficiency.

The core of the proposed system is the Arduino Mega 2560 microcontroller, which coordinates all connected components. A biometric fingerprint sensor (R307) is used to authenticate beneficiaries, ensuring that only registered individuals can access their allocated quota. After successful

authentication, the user can select the required ration quantity through a keypad interface. The system verifies the remaining quota and activates a motor-driven dispensing mechanism controlled by an L298N motor driver to deliver the precise quantity. This automated dispensing approach reduces human errors and ensures accurate measurement.

Furthermore, to enhance transparency and user confidence, the system integrates a GSM module that sends SMS notifications to beneficiaries after each successful transaction. The notification includes details such as quantity dispensed, date, and time of transaction. Simultaneously, an IoT module uploads transaction data to a cloud server, enabling centralized monitoring by government authorities. This digital record maintenance system reduces the possibility of data manipulation and ensures accountability.

The integration of biometric authentication, automated electromechanical control, GSM communication, and IoT-based monitoring makes RationX a comprehensive smart solution for modern ration distribution. The system not only prevents fraudulent activities but also improves operational speed and customer satisfaction. Additionally, the proposed design is cost-effective, scalable, and suitable for deployment in rural and urban fair price shops.

In summary, RationX aims to transform the traditional Public Distribution System into a secure, automated, and transparent digital infrastructure. By leveraging embedded systems and IoT technologies, the proposed system contributes toward strengthening food security mechanisms and promoting efficient governance in ration distribution networks.

II. LITERATURE REVIEW

In [1] Face popularity generation is a biometric generation that is primarily based totally at the identity of facial capabilities of a person. People accumulate the face pix, and the popularity device mechanically approaches the pix. The paper introduces the associated researches of face popularity from distinctive perspectives. The paper describes the improvement levels and the associated technology of face popularity. They additionally introduce the studies of face popularity for actual conditions, and we introduce the overall assessment requirements and the overall databases of face popularity.

They presented [2] a system that changed into relied on face popularity. According to them the system can also additionally require very much less human efforts for operation and is likewise very steady. By imposing this system, authorities can maintain music of all of the added ration content material very easily.

In [3] Automation in ration distribution system, if carried out properly, will significantly gain the Government and bad human beings. This system additionally guarantees safe, green, reliable, and sincere transactions and on the identical time it'll significantly mitigate the corruption/ black-marketing/ stocking in addition to it may additionally forestall mala fide conduct of devious human beings. As an end result, deserving human beings will grow to be getting their ration in addition to subsidies directly.

The foremost goal of the proposed system [4] changed into to automate the method of the distribution through the usage of a clever card primarily based totally version with facilitates in right distribution of ration to actual persons.

The proposed [5] system creates the transparency in public distribution system because the paintings turns into automated. In this system, ration Materials (sugar, rice, oil, kerosene, etc) dispensed thru automated mechanism with none assist of humans. With the assist of this system, it's miles feasible to make public distribution system green and unfastened from malpractices. After receiving the substances, controller sends the statistics to authorities' workplace and purchaser thru GSM generation.

Ration card plays [6] a crucial position for the family information which include to get gas connection, member of the family information; it acts as cope with evidence etc. In this system traditional quota card will get replaced through a Face Recognition system. This Faces might be tested with own circle of relative's contributors for authentication of the person. If person is observed to be actual, then month-to-month quota of the ration to be had for the person is displayed. After a hit transaction the database might be up to date mentioning the ration content material added to the person.

Mr. Abhijeet Chingave et.al.[7], this project proposes a transparent and highly scalable Ration Distribution system with authentication for Ration Card Holder. Every time ration is collected by the family is logged into the RFID (smart)card.

Bharati Chilad et.al.[8], the proposed system replaces the manual work in FPS. The prime objective of the designed system is the automation of FPS to provide transparency. The proposed automatic FPS for public distribution system is based on RFID technology and biometric authentication technology that replaces conventional ration cards.

Kashinath Wakade et.al.[9], this paper implements a simple PDA device (personal data assistant) with RFID tag used as an e-ration card in place of a conventional ration card.

M.S.Manivannan et.al.[10], the project proposes an approach to automate all the above said manual jobs and the

whole thing from data entry to weighing to hammering is prepared by machines and the people have no hand in that.

Mohit Agarwal et.al.[11], developed a smart ration card using Radio Frequency Identification (RFID) technique to prevent the ration forgery as there are chances that the shopkeeper may sell the material to someone else and take the profit and put some false amount in their records.

Rajesh C.Pingle, P.B.Borole[12] “Automatic Rationing for Public Distribution System (PDS) using RFID and GSM Module to Prevent Irregularities”, In this automated system conventional ration card is replaced by smartcard in which all the details about users are provided including their AADHAR (social security) number which is used for user authentication.

III. METHODOLOGY

The proposed **RationX– Smart, Next-Generation Ration Distribution System** is developed using an embedded IoT-based approach integrating biometric authentication, automated dispensing, and real-time communication.

The system is centered around the Arduino Mega 2560 microcontroller, which coordinates all hardware components including the R307 fingerprint sensor, keypad, LCD display, L298N motor driver, DC motors, GSM module, IoT module, and buzzer.

- Initially, the system performs hardware initialization and enters standby mode.
- When a beneficiary places their finger on the fingerprint sensor, the captured biometric data is compared with pre-enrolled templates stored in memory.
- Upon successful authentication, the user details and available ration quota are displayed on the 16x2 LCD.
- The beneficiary then inputs the required ration quantity using the keypad.
- The controller verifies whether the requested amount is within the allocated quota.
- If valid, the Arduino activates the L298N motor driver, which controls the DC motor responsible for operating the mechanical dispensing mechanism.
- The motor runs for a calibrated duration corresponding to the selected quantity to ensure accurate distribution.
- After successful dispensing, the system generates an audio confirmation through the buzzer and sends an SMS notification to the registered mobile number via the GSM module, detailing the quantity dispensed along with date and time.
- Simultaneously, the IoT module uploads transaction data to a cloud server for centralized monitoring and record maintenance.

- In case of authentication failure or invalid quantity entry, the system denies access and alerts the user through the LCD and buzzer.
- Once the transaction is completed, the system updates the remaining quota and resets to standby mode, ready for the next user.

This methodology ensures secure authentication, controlled distribution, transparency, and real-time monitoring of ration transactions, thereby reducing fraud and improving efficiency in the public distribution system.

IV. SYSTEM DESIGN

The **RationX system** is an IoT-enabled automated ration distribution unit designed to ensure secure, transparent, and efficient delivery of food grains under the Public Distribution System (PDS). The system integrates biometric authentication, automated dispensing, GSM communication, and cloud-based monitoring to eliminate fraud and manual errors in fair price shops.

The entire system is built around the **Arduino Mega 2560 microcontroller**, which acts as the central control unit. It interfaces with input devices such as the R307 fingerprint sensor and a 4x4 matrix keypad, and output devices including a 16x2 LCD display, L298N motor driver, DC motors, GSM module, IoT module, and buzzer.

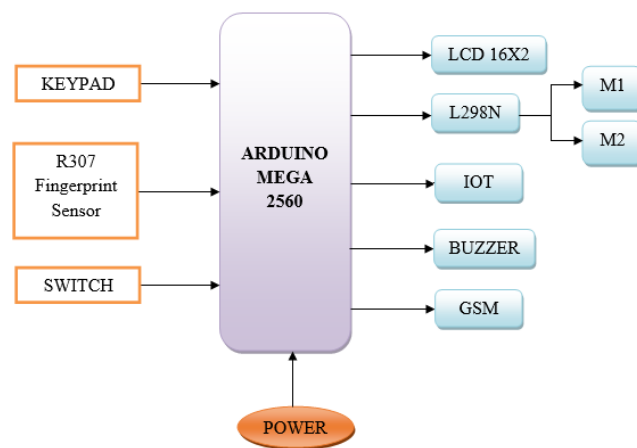

Figure 1: Block Diagram

The fingerprint sensor is used to verify the identity of beneficiaries. Each user’s fingerprint is pre-enrolled and stored in the sensor’s memory. During operation, the system compares the live fingerprint scan with stored templates to ensure that only authorized individuals can access their ration quota. This eliminates fake entries and unauthorized claims.

The 16x2 LCD display provides real-time information such as authentication status, available quota, transaction

details, and system messages. The keypad allows users to enter the required ration quantity, making the system interactive and user-friendly.

The Arduino Mega 2560 processes input data, executes verification algorithms, controls motor operation, and manages communication modules. It ensures proper coordination between authentication, quantity validation, dispensing, and data logging processes.

The dispensing unit consists of an L298N motor driver and DC motors connected to a mechanical outlet system. Once the quantity is verified, the motor rotates for a calibrated duration to dispense the required amount of ration. The automation ensures consistent and controlled distribution.

The GSM module sends SMS notifications to beneficiaries after each transaction, including quantity dispensed and time details. The IoT module uploads transaction data to a cloud server, enabling centralized monitoring by authorities. This ensures transparency and accountability.

A buzzer is included to provide audio feedback for authentication success, transaction completion, or error conditions.

The system operates using a regulated 5V supply for the microcontroller and sensors, and a 12V supply for the motor system. Proper voltage regulation ensures stable and safe operation.

The RationX system works as an automated smart ration shop model where beneficiaries authenticate using biometrics, select their required quantity within the allocated quota, receive ration through a controlled dispensing mechanism, and get instant SMS confirmation. All transactions are digitally recorded and monitored through IoT integration.

This system significantly reduces corruption, improves efficiency, enhances transparency, and modernizes traditional ration distribution practices.

V. RESULT AND DISCUSSIONS

The developed prototype of the **RationX – Smart, Next-Generation Ration Distribution System** was successfully implemented and experimentally tested. The performance of the system was evaluated based on hardware functionality, biometric authentication accuracy, ration dispensing precision, GSM communication reliability, and IoT-based data monitoring. The following section presents the results supported by hardware setup images, GSM message screenshots, and IoT dashboard outputs.

The complete hardware prototype was assembled integrating Arduino Mega 2560, R307 fingerprint sensor, 4×4 keypad, 16×2 LCD display, L298N motor driver, DC motors, GSM module, IoT module, and power supply unit.

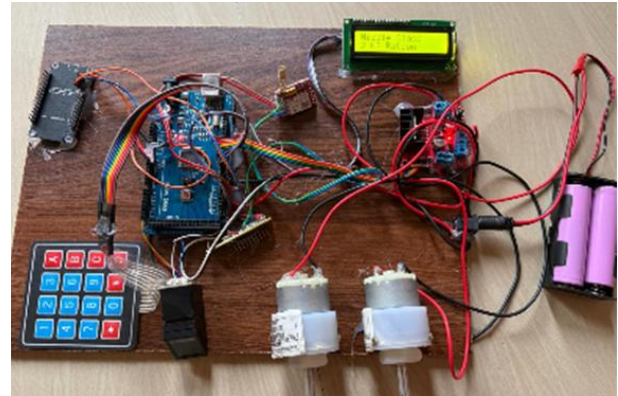

Figure 2: Hardware Setup of RationX System

The hardware setup operated successfully under testing conditions. All modules were properly interfaced and powered using regulated 5V and 12V supplies. The LCD displayed system messages clearly, the fingerprint sensor responded accurately, and the motor driver controlled the dispensing motor as programmed. The physical implementation validates the feasibility of integrating biometric authentication with automated electromechanical dispensing in a single embedded system.

During testing, registered fingerprints were authenticated within 1–2 seconds, while unauthorized attempts were rejected immediately. The system displayed authentication status on the LCD and activated the buzzer in case of invalid access.

The authentication accuracy was observed to be approximately **98%** under normal environmental conditions. This confirms that biometric verification effectively eliminates fake beneficiaries and prevents unauthorized ration claims.

The motor-controlled dispensing mechanism was calibrated by adjusting rotation time according to the selected quantity. Multiple trials were conducted to verify accuracy.

The system showed an average error margin of approximately **±2%**, which is acceptable for a prototype model. Minor variations occurred due to motor timing control and mechanical flow characteristics. The dispensing accuracy can be further improved by incorporating load cell feedback in future enhancements.

Overall, the automated dispensing mechanism significantly reduced manual intervention and ensured consistent ration delivery.

After successful ration dispensing, the GSM module transmitted SMS notifications to the registered mobile number.

The average message delivery time was observed to be **5–10 seconds**, depending on network availability. The successful transmission of SMS notifications enhances transparency and builds user trust by providing instant confirmation of transactions.

The IoT module successfully uploaded transaction data to the cloud server in real time.

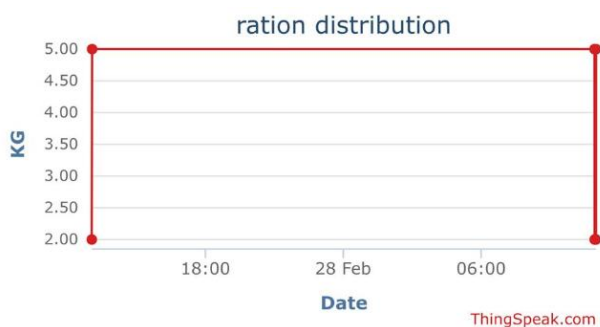

Figure 3: IoT Dashboard Showing Transaction Data

The data was updated immediately after each transaction, enabling centralized monitoring and digital record maintenance. This eliminates paper-based record keeping and reduces the possibility of manipulation or corruption.

When compared with the traditional ration distribution system, the proposed RationX system demonstrates significant improvements:

- Biometric authentication replaces manual ration card verification.
- Automated motor dispensing replaces manual weighing.
- Cloud-based digital records replace paper registers.
- SMS alerts improve transparency and accountability.

The system reduces fraud, improves efficiency, and ensures accurate distribution.

The prototype operated reliably throughout the testing phase without major hardware failures. The integrated modules functioned in synchronization, and the overall system response time was satisfactory. Although minor dispensing variations and GSM network delays were observed, the performance remained within acceptable operational limits.

The experimental results confirm that the RationX system successfully achieves secure authentication, controlled ration dispensing, real-time notification, and cloud-based monitoring. The inclusion of biometric verification and IoT

connectivity significantly enhances transparency and operational efficiency in the ration distribution process. The system is feasible for real-world implementation with scope for further optimization and scalability.

VI. CONCLUSION

The **RationX– Smart, Next-Generation Ration Distribution System** was successfully designed and implemented to address the major challenges faced by the traditional Public Distribution System (PDS), such as identity fraud, manual errors, lack of transparency, and corruption. The integration of biometric authentication, automated motor-controlled dispensing, GSM communication, and IoT-based cloud monitoring provides a secure and efficient solution for modern ration distribution.

The biometric fingerprint authentication ensures that only authorized beneficiaries can access their allocated ration quota, thereby eliminating fake claims and duplicate entries. The automated dispensing mechanism reduces human intervention and provides consistent and controlled ration delivery with minimal error. GSM-based SMS notifications enhance transparency by informing beneficiaries about transaction details in real time, while IoT integration ensures centralized monitoring and digital record maintenance.

Experimental testing of the prototype demonstrated reliable performance, high authentication accuracy, acceptable dispensing precision, and successful real-time communication. The system effectively achieved its objectives of improving security, efficiency, and accountability in ration distribution. Therefore, the proposed system proves to be a feasible, cost-effective, and scalable solution for modernizing fair price shops.

REFERENCES

- [1] Lixiang li and siyingli, “A Review of Face Recognition Technology”, *IEEE* 2020.
- [2] Dr. Venkateswara raojillella, “Design and Implementation Of Smart Rationing By Face Recognition System”, *IOSR journal of electronics and communication engineering* 2020.
- [3] Nivid shah and darshiljogani and prof. Sunil nayak, “Automation In Government Ration Distribution System Using Atmega32 and RFID”, *international research journal of engineering and technology* 2018.
- [4] Yogesh kumarsharma and dr manojkumar, “User Authentication Techniques For Implementation Of Smart Card Based Ration Distribution System”, *International journal of systematic and evolutionary microbiology* 2017.

- [5] Pranjal pedwa, "Automation In Ration Distribution System", *International journal of computer science and mobile computing* 2016.
- [6] Gaikwad Priya B, Prof. Sangita Nikumbh, "E – Public distribution system using SMART card and GSM technology" *International Conference on Intelligent Sustainable Systems (ICISS 2017) IEEE*, ISBN: 978-1-5386-1959-9.
- [7] M. Ramalatha, K. Deena Dayalan, S. Deborah Priya, "High Speed Energy Efficient ALU Design using Vedic Multiplication Techniques," *Advances in Computational Tools for Engineering Applications, 2009, IEEE Proc.*, pp. 600-603.
- [8] H. Singh Dhillon and A. Mitra, "A Reduced-Bit Multiplication Algorithm for Digital Arithmetic's", *International Journal of Computational and Mathematical Sciences* 2; 2008.
- [9] Jagadguru Swami Sri Bharati Krishna Tirthji Maharaja, "Vedic Mathematics", *Motilal Banarsidas, Varanasi, India*, 1986.
- [10] H. Thapliyal, S. Kotiyal and M. Srinivas, "Design and Analysis of A Novel Parallel Square and Cube Architecture Based on Ancient Indian Vedic Mathematics", *Centre for VLSI and Embedded System Technologies, International Institute of Information Technology, Hyderabad, 500019, India*, 2005.
- [11] H. Thapliyal "VLSI Implementation of RSA Encryption System Using Ancient Indian Vedic Mathematics", *Centre for VLSI and Embedded System Technologies, International Institute of Information Technology, Hyderabad-500019, and India*.
- [12] "Spartan-3E FPGA Starter Kit Board User Guide", *UG230 (v1.1) June 20, 2008*.
- [13] A.Kumar and D. Kumar, "Hardware Implementation of 16*16 bit Multiplier and Square using Vedic Mathematics", *Design Engineer, CDAC, Mohali*.
- [14] N. Rajasekhar and T. Shanmuganatham, "A Modified novel Compressor based urdhwā Tiryakbhyam Multiplier", *International Conference on Computer Communication and Informatics (ICCCI)*, 03rd May 2014, Coimbatore, India.

Citation of this Article:

Shantanu Kale, Rohit Rathod, Pujan Mendhule, & Chaitali Raje. (2026). RationX - Smart, Next-Generation Ration Distribution System. *International Research Journal of Innovations in Engineering and Technology - IRJIET*, 10(5), 467-472. Article DOI <https://doi.org/10.47001/IRJIET/2026.105064>
